

KINTEK

CARTRIDGES - CARTUCCE



CARTRIDGES 

EINBAUHALTER 

КАРТРИДЖИ 

CARTOUCHES 

CARTUCCE 

刀头 

EINBAUHALTER
CARTRIDGES
КАРТРИДЖИ
CARTOUCHES
CARTUCCE
刀头

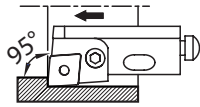

PCLN
Page 520

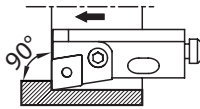

PCFN
Page 520

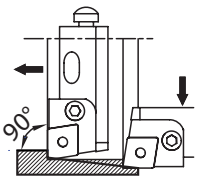

PCGN
Page 521

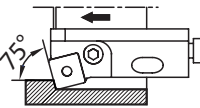

PSKN
Page 521

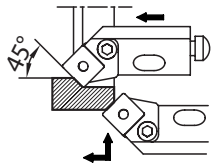

PSSN
Page 522

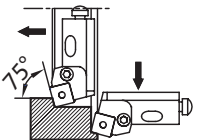

PSRN
Page 522

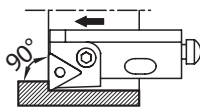

PTFN
Page 523

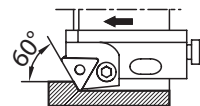

PTWN
Page 523

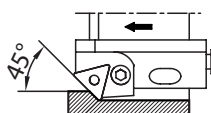

PTSN
Page 524

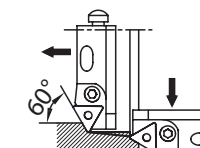

PTTN
Page 524

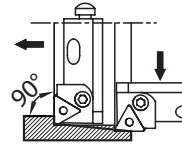

PTGN
Page 525

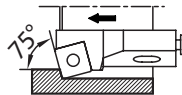

SSKC
Page 525

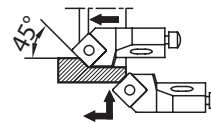

SSSC
Page 526



SCLC
Page 526

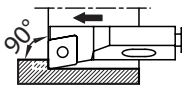

SCFC
Page 527

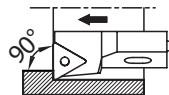

STFC
Page 527

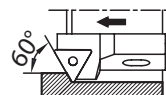

STWC
Page 528

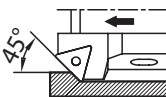

STSC
Page 528

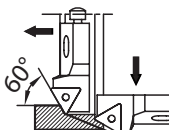

STTC
Page 529

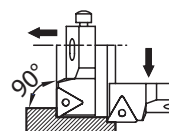

STGC
Page 529

BESTELNUMMERN-SCHLÜSSEL FÜR EINBAUHALTER
 CODE KEY FOR CARTRIDGES
 СИСТЕМА ОБОЗНАЧЕНИЯ КАРТРИДЖЕЙ

CODIFICATION DES CARTOUCHES
 CHIAVE DEI CODICI DELLE CARTUCCE
 刀头代码键

①

Spannsystem
Clamping system
Système de serrage
Sistema di bloccaggio
Система крепления СМП
夹紧系统

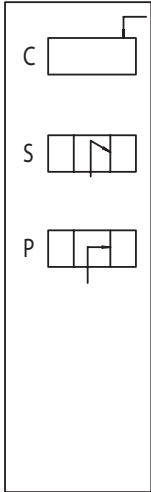

②

Platteform
Insert Shape
Forme des plaquettes
Forma degli inserti
Форма пластины
插件形状

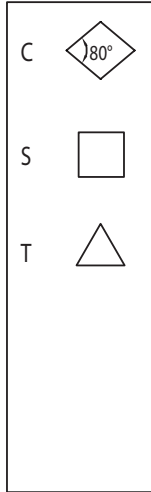

③

Einbauhalterauführung, Einstellwinkel
Cartridge style, entering angle
Type de cartouche, angle d'attaque
Tipo di cartuccia, angolo di registrazione
Угол в плане
刀头样式, 进刀角度

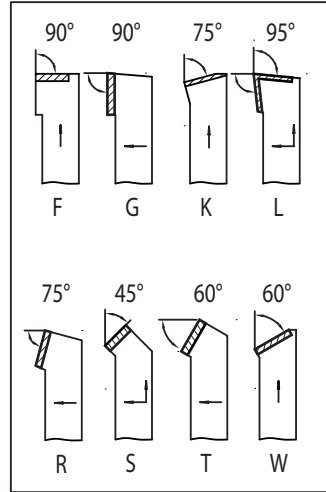

④

Freiwinkel
Clearance angle
Angle de depouil
Angolo di spoglio
Задний угол
间隙角度

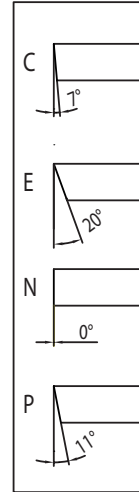

⑤

Vorshubrichtung
Feeding direction
Sens de l'avance
Senso di avanzamento
Исполнение (прав./лев.)
进给方向

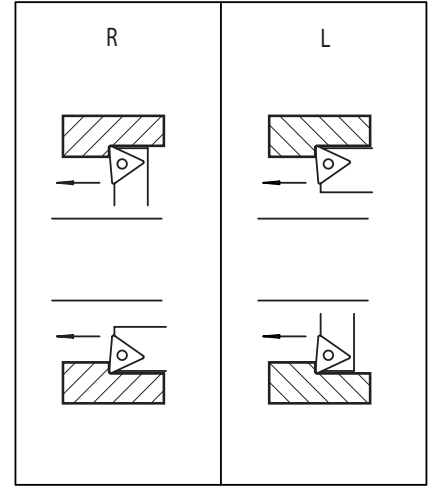

P C L N R 16 C A - 12

① ② ③ ④ ⑤ ⑥ ⑦ ⑧ ⑨ ⑩

⑥

Schneidkantenhöhe
Cutting edge height
Hauteur de l'arête de coupe
Altezza del tagliente
Высота режущей кромки
切削刃高度

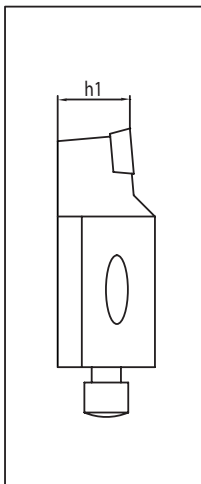

⑦

Haltertyp
Type of tool
Type d'outil
Tipo di utensile
Тип инструмента
工件类型

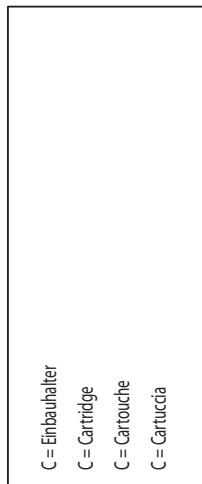

⑧

Ausführung
Type of design
Construction
Tipo di progetto
Тип конструкции
设计类型

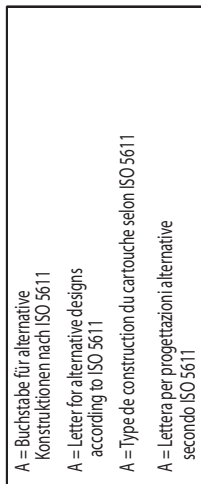

⑨

Werkzeuglänge
Tool length
Longueur de l'outil
Lunghezza utensile
Длина инструмента
工件长度

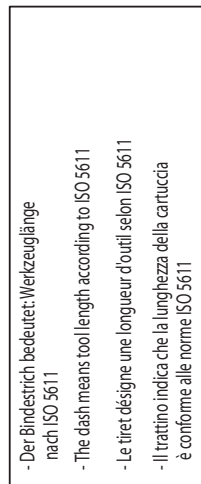

⑩

Schneidkantenlänge
Insert cutting edge length
Longueur des arêtes des plaquettes
Lunghezza del profilo inserto
Длина режущей кромки
插件的切削边缘长度

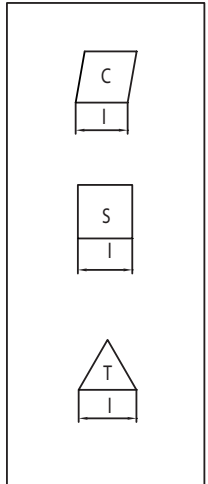

PCLN

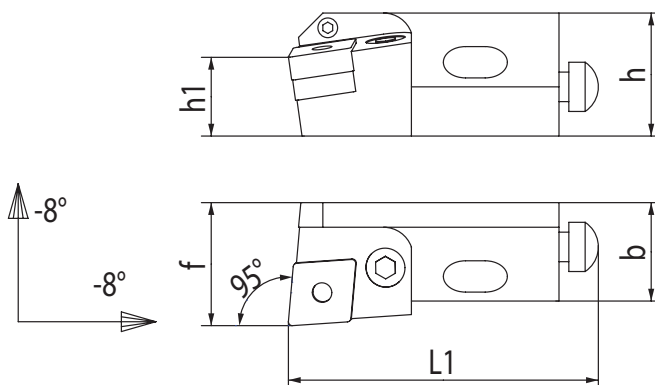

Code N.	h	h1	b	L1	f	Dmin.	Inserts N.	Support pad	Lever	Screw	Shimpin	Chiave
PCLNR/L 12CA-12	20	12	15	55	20	50	CNM..1204..					2.5
PCLNR/L 16CA-12	25	16	20	63	25	55	CNM..1204..	KA1	K112	K122	KD1	3
PCLNR/L 20CA-16	30	20	20	70	25	70	CNM..1606..	KY2	KB5	KC5c	KD5	3
PCLNR/L 25CA-19	38	25	25	100	32	100	CNM..1906..	KA2	K113	K123	K131	4

PCFN

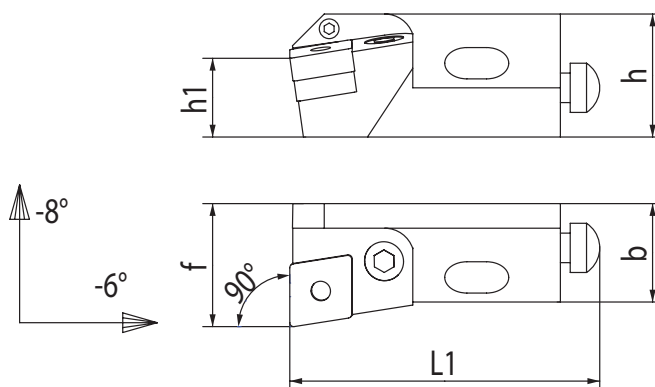

Code N.	h	h1	b	L1	f	Dmin.	Inserts N.	Support pad	Lever	Screw	Shimpin	Chiave
PCFNR/L 12CA-12	20	12	15	55	20	50	CNM..1204..					2.5
PCFNR/L 16CA-12	25	16	20	63	25	55	CNM..1204..	KA1	K112	K122	KD1	3
PCFNR/L 20CA-16	30	20	20	70	25	70	CNM..1606..	KY2	KB5	KC5c	KD5	3
PCFNR/L 25CA-19	38	25	25	100	32	100	CNM..1906..	KA2	K113	K123	K131	4

PCGN

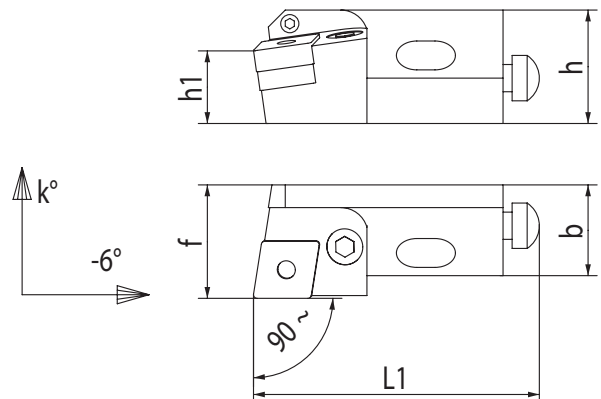

Code N.	h	h1	b	L1	f	Dmin.	k	Inserts N.	Support pad	Lever	Screw	Shimpin	Chiave
PCGNR/L 16CA-12	25	16	20	63	25	60	-10°	CNM..1204..					
PCGNR/L 25CA-19	38	25	25	100	32	100	-8°	CNM..1906..					

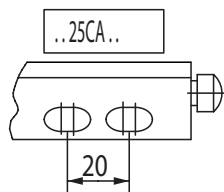

Ricambi cartucce per ...	Screw	Chiave	Screw	Screw	Chiave
..12CA..	KGRL12	2	KVA5	KVB12	4
..16CA..	KGRL16	2.5	KVA6	KVB16	5
..20CA..	KGRL20	2.5	KVA6	KVB20	5
..25CA..	KGRL25	3	KVA8	KVB25(n°2)	6

PSKN

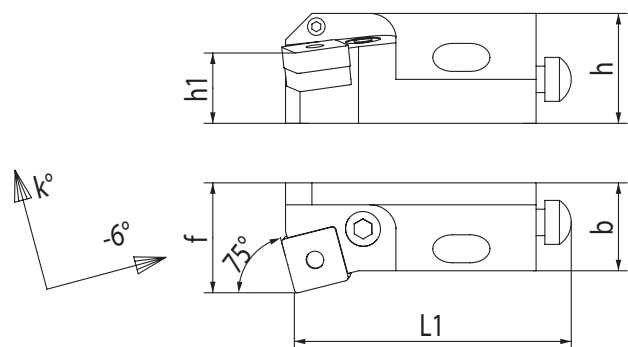

Code N.	h	h1	b	L1	f	Dmin.	k	Inserts N.	Support pad	Lever	Screw	Shimpin	Chiave
PSKNR/L 12CA-12	20	12	15	55	20	50	-8°	SNM..1204..					2.5
PSKNR/L 16CA-12	25	16	20	63	25	55	-7°	SNM..1204..					3
PSKNR/L 20CA-15	30	20	20	70	25	70	-8°	SNM..1506..					3
PSKNR/L 25CA-19	38	25	25	100	32	100	-7°	SNM..1906..					4

PSSN

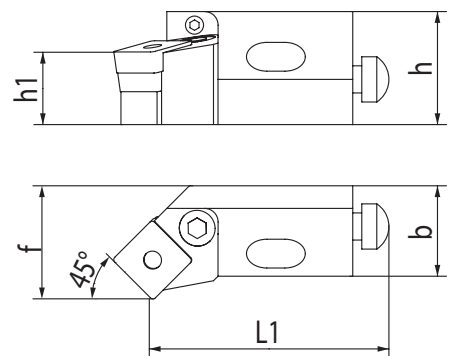

Code N.	h	h1	b	L1	f	Dmin.	k1	k2	Inserts N.	Support pad	Lever	Screw	Shimpin	Chiave
PSSNR/L 12CA-12	20	12	15	47	20	50	-3°	-10°	SNM..1204..					
PSSNR/L 16CA-12	25	16	20	53	25	55	0°	-11°	SNM..1204..	KA4	K112	K122	KD1	3
PSSNR/L 20CA-15	30	20	20	60	25	70	-3°	-10°	SNM..1506..	KY1	KB5	KC5c	KD5	3

PSRN

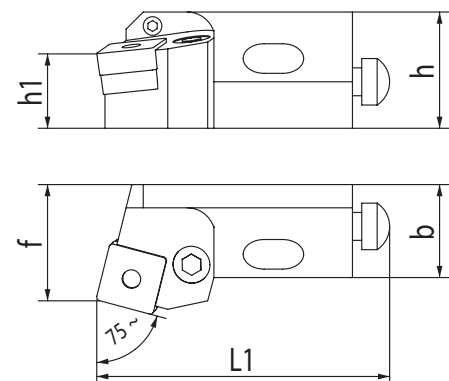
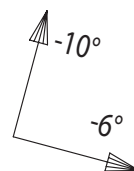

Code N.	h	h1	b	L1	f	Dmin.	Inserts N.	Support pad	Lever	Screw	Shimpin	Chiave
PSRNR/L 16CA-12	25	16	20	63	25	60	SNM..1204..					
PSRNR/L 20CA-15	30	20	20	70	25	70	SNM..1506..	KY1	KB5	KC5c	KD5	3

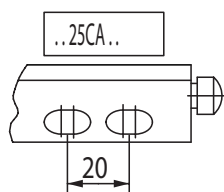

Ricambi cartucce per ...	Screw	Chiave	Screw	Screw	Chiave
..12CA..	KGRL12				
..16CA..	KGRL16	2.5	KVA6	KVB16	5
..20CA..	KGRL20	2.5	KVA6	KVB20	5
..25CA..	KGRL25	3	KVA8	KVB25(n°2)	6

PTFN

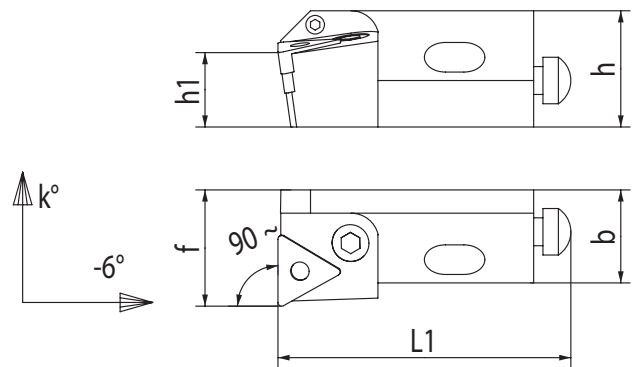

Code N.	h	h1	b	L1	f	Dmin.	k	Inserts N.	Support pad	Lever	Screw	Shimpin	Chiave	
PTFNR/L 12CA-16	20	12	15	55	20	50	-9°	TNM..1604..						2
PTFNR/L 16CA-16	25	16	20	63	25	55	-8°	TNM..1604..	KA6	KB4	KC3	KD3		2.5
PTFNR/L 20CA-22	30	20	20	70	25	70	-8°	TNM..2204..	KA7	KB1	KC1	KD1		3
PTFNR/L 25CA-27	38	25	25	100	32	100	-9°	TNM..2706..	KH1	KH2	KH5	KD5		3

PTWN

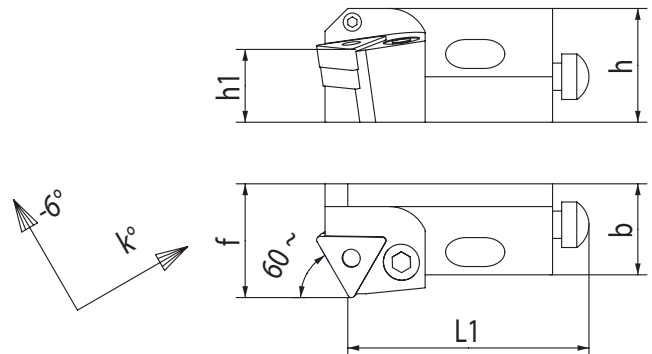

Code N.	h	h1	b	L1	f	Dmin.	k	Inserts N.	Support pad	Lever	Screw	Shimpin	Chiave	
PTWNR/L 12CA-16	20	12	15	47	20	50	-7°	TNM..1604..						2
PTWNR/L 16CA-16	25	16	20	53	25	55	-6°	TNM..1604..	KA6	KB4	KC3	KD3		2.5
PTWNR/L 20CA-22	30	20	20	60	25	70	-6°	TNM..2204..	KA7	KB1	KC1	KD1		3

PTSN

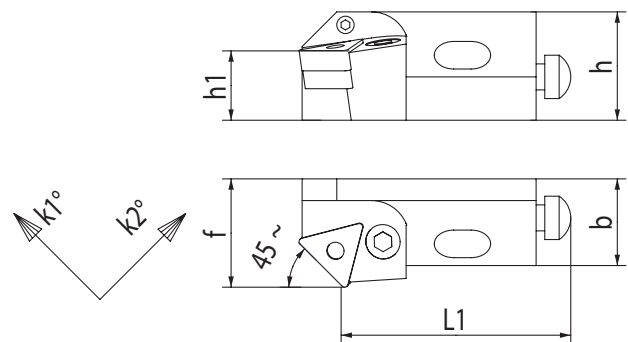

Code N.	h	h1	b	L1	f	Dmin.	k1	k2	Inserts N.	Support pad	Lever	Screw	Shim pin	Chiave
PTSNR/L 12CA-16	20	12	15	47	20	50	-3°	-10°	TNM..1604..					
PTSNR/L 16CA-16	25	16	20	53	25	55	0°	-11°	TNM..1604..	KA6	KB4	KC3	KD3	2.5
PTSNR/L 20CA-22	30	20	20	60	25	70	0°	-11°	TNM..2204..	KA7	KB1	KC1	KD1	3

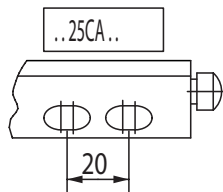

Ricambi cartucce per ...	Screw	Chiave	Screw	Screw	Chiave
..12CA..	KGRL12	2	KVA5	KVB12	4
..16CA..	KGRL16	2.5	KVA6	KVB16	5
..20CA..	KGRL20	2.5	KVA6	KVB20	5
..25CA..	KGRL25	3	KVA8	KVB25(n°2)	6

PTTN

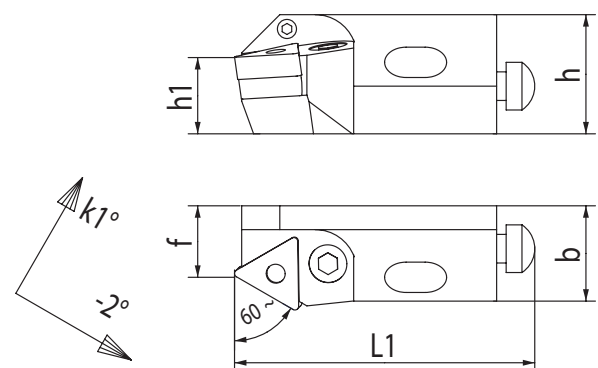

Code N.	h	h1	b	L1	f	Dmin.	k	Inserts N.	Support pad	Lever	Screw	Shim pin	Chiave
PTTNR/L 12CA-16	20	12	15	55	13	50	-9°	TNM..1604..					
PTTNR/L 16CA-16	25	16	20	63	15	60	-10°	TNM..1604..	KA6	KB4	KC3	KD3	2.5
PTTNR/L 20CA-22	30	20	20	70	15	70	-10°	TNM..2204..	KA7	KB1	KC1	KD1	3

PTGN

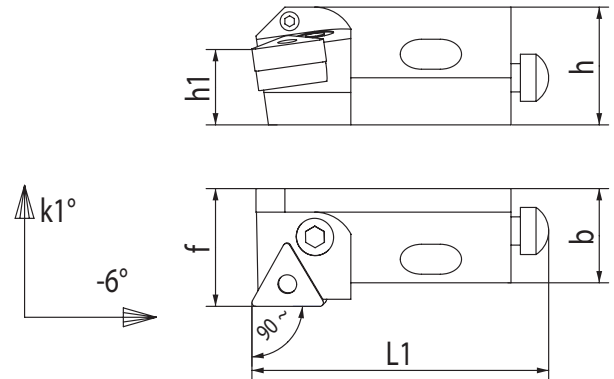

Code N.	h	h1	b	L1	f	Dmin.	k	Inserts N.	Support pad	Lever	Screw	Shimpin	Chiave
PTGNR/L 12CA-16	20	12	15	55	20	50	-10°	TNM..1604..		K111	K121		2
PTGNR/L 16CA-16	25	16	20	63	25	60	-10°	TNM..1604..	KA6	KB4	KC3	KD3	2.5
PTGNR/L 20CA-22	30	20	20	70	25	70	-8°	TNM..2204..	KA7	KB1	KC1	KD1	3

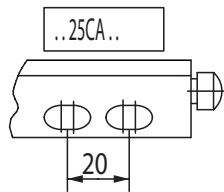

Ricambi cartucce per ...	Screw	Chiave	Screw	Screw	Chiave
..12CA..	KGRL12	2	KVA5	KVB12	4
..16CA..	KGRL16	2.5	KVA6	KVB16	5
..20CA..	KGRL20	2.5	KVA6	KVB20	5
..25CA..	KGRL25	3	KVA8	KVB25(n°2)	6

SSKC

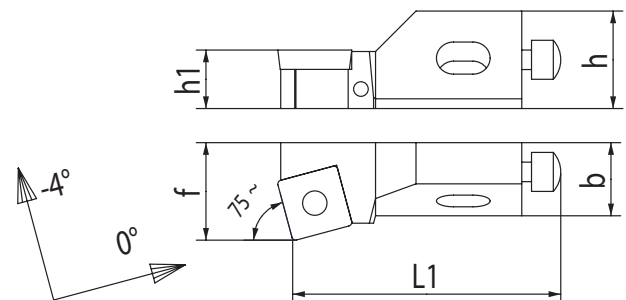

Code N.	h	h1	b	L1	f	Dmin.	Inserts N.	Screw	Wrench
SSKCR/L 10CA-09	15	10	11	50	14	40	SCM..09T3..	KV4c	Torx 15
SSKCR/L 12CA-12	20	12	15	55	20	50	SCM..1204..	KV5	Torx 20

SSSC

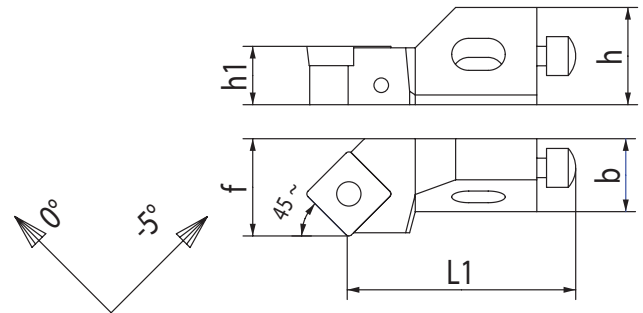

Code N.	h	h1	b	L1	f	Dmin.	Inserts N.
SSSCR/L 10CA-09	15	10	11	44	14	40	SCM..09T3..
SSSCR/L 12CA-12	20	12	15	47	20	50	SCM..1204..

Screw	Wrench
KV4c	Torx 15
KV5	Torx 20

SCLC

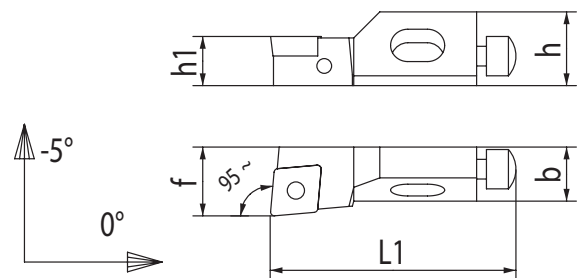

Code N.	h	h1	b	L1	f	Dmin.	Inserts N.
SCLCR/L 10CA-09	15	10	11	50	14	40	CCM..09T3..
SCLCR/L 12CA-12	20	12	15	55	20	50	CCM..1204..

Screw	Wrench
KV4c	Torx 15
KV5	Torx 20

SCFC

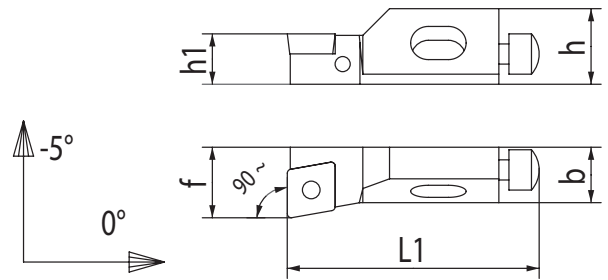

Code N.	h	h1	b	L1	f	Dmin.	Inserts N.	Screw	Wrench
SCFCR/L 10CA-09	15	10	11	50	14	40	CCM..09T3..		
SCFCR/L 12CA-12	20	12	15	55	20	50	CCM..1204..		

Ricambi cartucce per ...	Screw	Chiave	Screw	Screw	Chiave
..10CA..					
..12CA..					

STFC

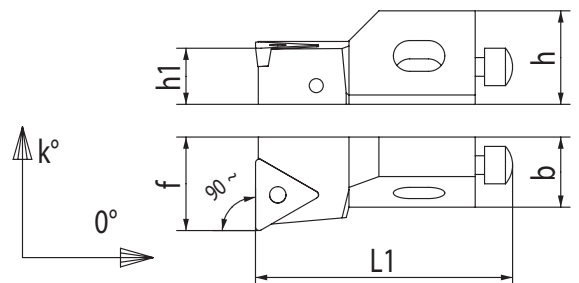

Code N.	h	h1	b	L1	f	Dmin.	k	Inserts N.	Screw	Wrench	Support pad	Bush	Chiave
STFCR/L 10CA-11	15	10	11	50	14	40	-3°	TCM..1102..					
STFCR/L 12CA-16	20	12	15	55	20	50	-3°	TCM..16T3..					
STFCR/L 16CA-16	21	16	20	63	25	55	-6°	TCM..16T3..					

STWC

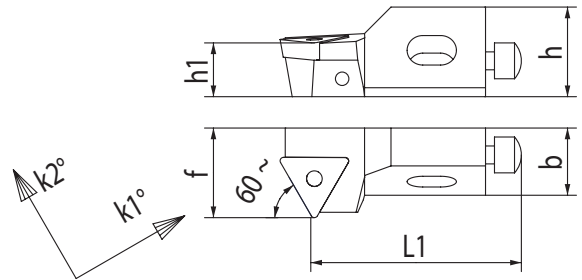

Code N.	h	h1	b	L1	f	Dmin.	k1	k2	Inserts N.	Screw	Wrench	Support pad	Bush	Chiave
STWCR/L 10CA-11	15	10	11	44	14	40	0°	-4°	TCM..1102..	KV25	Torx 7			
STWCR/L 12CA-16	20	12	15	47	20	50	-5°	0°	TCM..16T3..	KV4c	Torx 15			
STWCR/L 16CA-16	21	16	20	53	25	55	-5°	-5°	TCM..16T3..	KV35	Torx 15	KW3	KX01	3.5

STSC

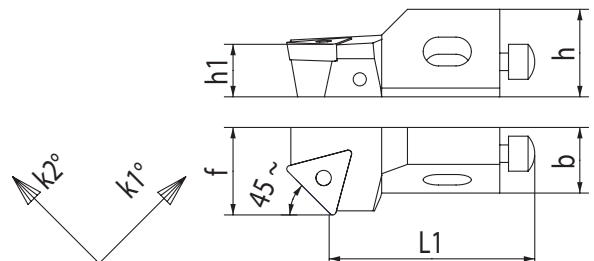

Code N.	h	h1	b	L1	f	Dmin.	k1	k2	Inserts N.	Screw	Wrench	Support pad	Bush	Chiave
STSCR/L 10CA-11	15	10	11	44	14	40	-4°	0°	TCM..1102..	KV25	Torx 7			
STSCR/L 12CA-16	20	12	15	47	20	50	-5°	0°	TCM..16T3..	KV4c	Torx 15			
STSCR/L 16CA-16	21	16	20	53	25	55	-6°	-3°	TCM..16T3..	KV35	Torx 15	KW3	KX01	3.5

Ricambi cartucce per ...	Screw	Chiave	Screw	Screw	Chiave
..10CA..	KGR10	2	KVA5	KVB10	4
..12CA..	KGR12	2	KVA5	KVB12	4
..16CA..	KGR16	2	KVA6	KVB16	5

STTC

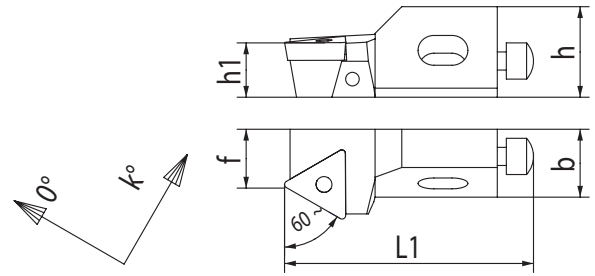

Code N.	h	h1	b	L1	f	Dmin.	k	Inserts N.	Screw	Wrench	Support pad	Bush	Chiave
STTCR/L 10CA-11	15	10	11	50	9	40	-5°	TCM..1102..					
STTCR/L 12CA-16	20	12	15	55	13	50	-3°	TCM..16T3..	KV4c	Torx 15			
STTCR/L 16CA-16	21	16	20	63	15	60	-5°	TCM..16T3..	KV35	Torx 15	KW3	KX01	3.5

STGC

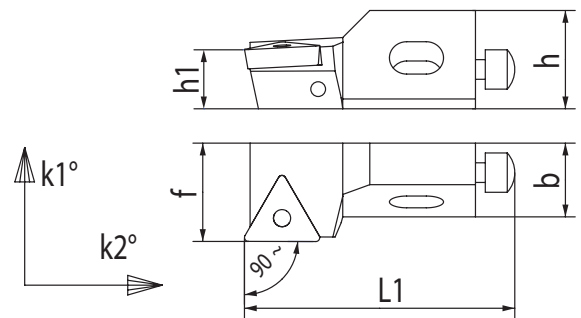

Code N.	h	h1	b	L1	f	Dmin.	k1	k2	Inserts N.	Screw	Wrench	Support pad	Bush	Chiave
STGCR/L 10CA-11	15	10	11	50	14	40	-3°	0°	TCM..1102..					
STGCR/L 12CA-16	20	12	15	55	20	50	-3°	0°	TCM..16T3..	KV4c	Torx 15			
STGCR/L 16CA-16	21	16	20	63	25	60	-5°	-3°	TCM..16T3..	KV35	Torx 15	KW3	KX01	3.5

Ricambi cartucce per ...	Screw	Chiave	Screw	Screw	Chiave
..10CA..					
..12CA..	KGR12	2	KVA5	KVB12	4
..16CA..	KGR16	2	KVA6	KVB16	5