

JOLLY

JOLLY B MINI-TOOL JOLLY Z MINI-MILL

MULTIFUNZIONALE
FACILE IMPIEGO
ALTA EFFICIENZA
BASSO COSTO



EUROPEAN INDUSTRIAL COMPONENTS

2022/03

jolly-001



UN UTENSILE... MOLTEPLICI LAVORAZIONI!

Ampia scelta di **STELI** in funzione del tipo di lavorazione ed attacco. Sono realizzati in acciaio speciale al cromo, molibdeno e vanadio (**THG 2000**), ad alta resistenza meccanica, eseguiti in **h5**, adatti per **calettamento a caldo**.

Ampia scelta di **INSERTI** in funzione del tipo di lavorazione e del materiale da lavorare. Sono realizzati con qualità in **grana ultrafine K20** ed affilati con precisione in **classe E**.

Due differenti tipologie di **rivestimenti ad alto rendimento**:

- **DEVIL** (D1) per acciai legati e inox legati, acciai al carbonio e ghise meehanite;
- **ZIRCONIO** (ZRN) per acciaio inox, alluminio e leghe non ferrose.

A richiesta si realizzano inserti per profili speciali e rivestimenti dedicati a materiali difficili.



JOLLY B MINI-TOOL

UTENSILI BILANCIATI A SINGOLO TAGLIENTE PER CENTRARE, SVASARE, TORNIRE, SFACCIARE, INCIDERE, SCANALARE, SMUSSARE E RAGGIARE SU CENTRI DI LAVORO, TORNII E PANTOGRAFI A CN.

JOLLY B è un utensile **Bilanciato** innovativo e **multifunzionale** per centri di lavoro, tornii e pantografi a CN.

Può montare sullo stesso gambo diverse **geometrie di inserti**, per lavorazioni singole, per **centrare, svasare, tornire, sfacciare, incidere, scanalare, smussare e raggiare**.

Con i **JOLLY B** si possono eseguire **infinite lavorazioni combinate** con un solo piazzamento sia sui mandrini in rotazione sia sulle stazioni statiche dei tornii.

JOLLY Z MINI-MILL

MINI-FRESE A SINGOLO O A QUATTRO TAGLIENTI PER FINIRE, FRESARE, SMUSSARE E RAGGIARE ANCHE SOTTOSQUADRA.

JOLLY Z è una serie di **Mini-Frese** dal **design compatto**, a **1 o a 4 taglienti** su diametro di taglio minimo!!!

Ideali per lavorazioni di **finitura** con **Ra ≤ 0,4 μm** (con steli Z4), **fresatura, smussatura e raggiatura** anche **sottosquadra**.

Altissime prestazioni tecnologiche: velocità di avanzamento fino al **400% in più** grazie alla **rigidità** del corpo fresa ed alla **qualità** degli inserti.

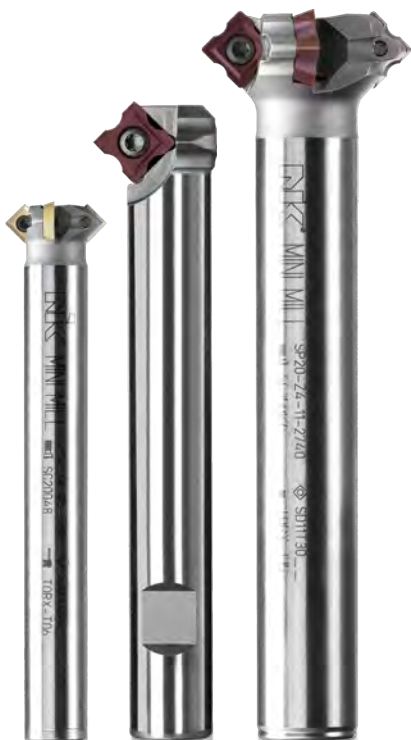

SP0606-S

SP1010-S

SP1614-S

SP2017-120D-S

SP1010-L

SP1614-L

SP2018-142D-S

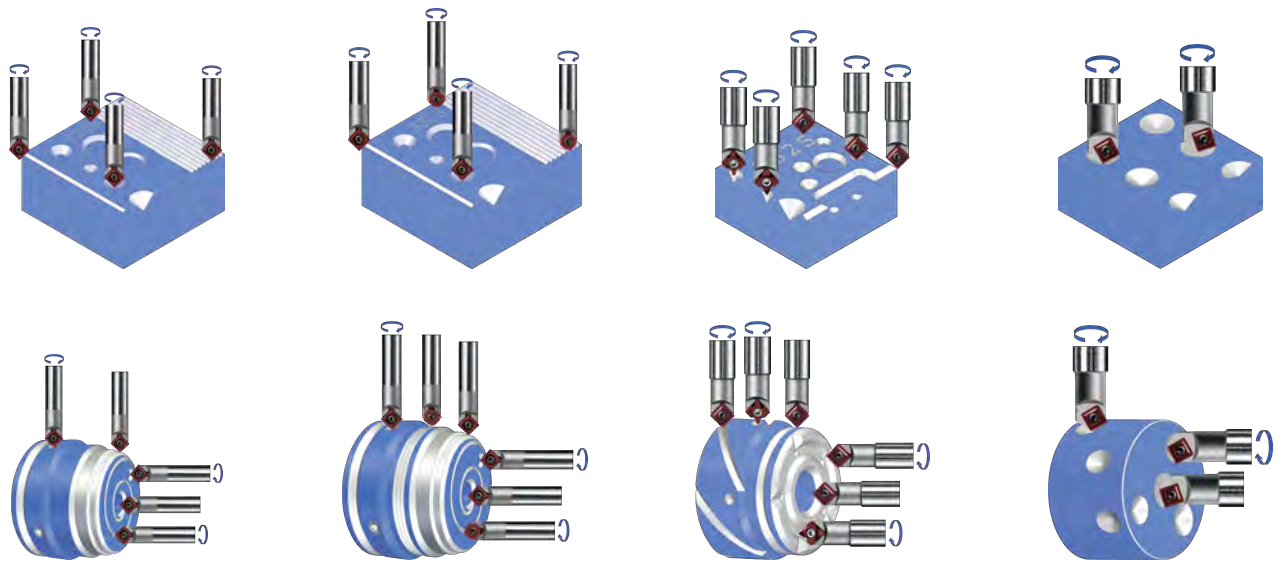

I DATI INDICATI NON SONO IMPEGNATIVI E POSSONO ESSERE MODIFICATI ANCHE SENZA PREAVVISO.

SCELTA DELL'INSERTO E SUE APPLICAZIONI

MODELLO STELO	TIPO DI LAVORAZIONE							ANGOLO				MATERIALE DA LAVORARE	RIVESTIMENTO
	CENTRARE	SVASARE	TORNIRE	SFACCIARE	INCIDERE	SCANALARE	SMUSSARE	60°	90°	120°	142°		
												ACCIAI LEGATI e INOX LEGATI ACCIAI AL CARBONIO GHISE MEEHANITE	DEVIL
												ACCIAIO INOX ALLUMINIO LEGHE NON FERROSE	ZRN
												MODELLO/TIPOLOGIA INSERTO	-D1 (DEVIL) -... = -ZRN
SP0606-S		●	●	●	●	●	●	●	●	●	●	SD050202CT-...	
SP1010-S		●	●	●	●	●	●	●	●	●	●	SD08020.CT-...	
SP1010-L					●	●		●				SD080201W60-...	
					●	●		●				SD080201W90-...	
SP1614-S		●	●	●	●	●	●	●	●	●	●	SD11T30.CT-...	
		(1)	(2)	(2)	(1)	(3)	(2)	(3)				SD11T30.CTP60-...	
		(2)	(2)	(2)	(2)	(2)						SD11T30.CTD20-... SD11T30.CTD25-... SD11T30.CTD315-...	(1) Fori da Centro (Simile DIN332 Forma R)
SP1614-L		(2)	(2)	(2)	(2)	(1)						SD11T308CTR10-... SD11T308CTR15-... SD11T308CTR20-... SD11T308CTR25-... SD11T308CTR30-...	
SP2017-120D-S		●	●			●				●		SD11T30.CT-...	
SP2018-142D-S		●	●			●				●			

(1) Lavorazioni ideali; (2)(3) Lavorazioni secondarie

JOLLY B Ø6MAX 30.000min⁻¹

•SP0606-S

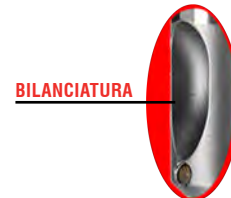
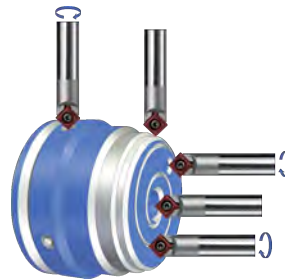
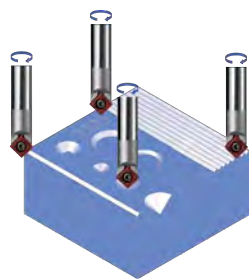

Utensile multifunzionale bilanciato a singolo tagliente per centrare, svasare, tornire, sfacciare, incidere, scanalare e smussare.

Ogni stelo viene fornito di:
1 Vite; 1 Chiave Torx.

In Optional:

inserti per varie tipologie di lavorazioni e materiali.

KIT Disponibili! (Stelo + Inserti)

•SP0606-S

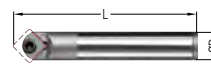

COD.	ØD [mm]	L [mm]	Vite (Inclusa)	Chiave (Inclusa)	Tipologia Inserti (Optional)
------	---------	--------	----------------	------------------	------------------------------

JOLLY B

STELI

SP0606-S	Ø6	40	SC20048	TORX-T6	SD050202CT-...
----------	----	----	---------	---------	----------------

RICAMBI

SC20048	Vite Torx M2,0x4,8 - 0,8Nm				
TORX-T6	Chiave Torx T6				



COD.	Rivestimento Inserto	Q [mm]	S [mm]	Re [mm]	H [mm]	Minimo Ordine
------	----------------------	--------	--------	---------	--------	---------------

INSERTI

SD050203CT-...

>> **MULTIFUNZIONE per:** Centrare, Svasare, Tornire, Sfaciare, Incidere, Scanalare e Smussare

SD050202CT-D1	DEVIL (HV 3800 ±200)	5,3	2	0,2	3,25	10 pz.
SD050202CT-ZRN	ZRN (HV 2500 ±300)			0,2	3,25	10 pz.

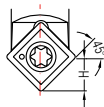
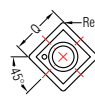
RIVESTIMENTO INSERTI: **DEVIL****KIT**RIVESTIMENTO INSERTI: **ZRN**

COD.
KS00 S CT D1



STELO	
1x SP0606-S	
INSERTI	VITI e CHIAVE
6x SD050202CT-D1	2x SC20048 1x TORX-T6

COD.
KS00 S CT ZRN



STELO	
1x SP0606-S	
INSERTI	VITI e CHIAVE
6x SD050202CT-ZRN	2x SC20048 1x TORX-T6

JOLLY B Ø10

MAX 20.000min⁻¹

- SP1010-S
- SP1010-L

Utensili multifunzionali bilanciati a singolo tagliente per centrare, svasare, tornire, sfacciare, incidere, scanalare e smussare.

Ogni stelo viene fornito di:
1 Vite; 1 Chiave Torx.

In Optional:

inserti per varie tipologie di lavorazioni e materiali.

KIT Disponibili! (Stelo + Inserti)

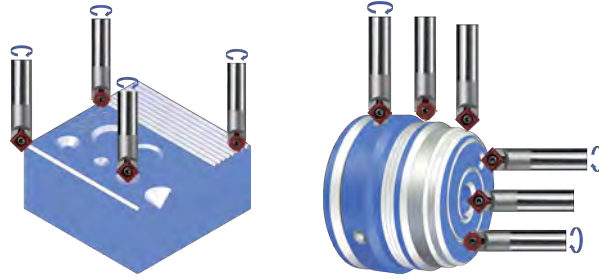

BILANCIATURA



- SP1010-S
- SP1010-L

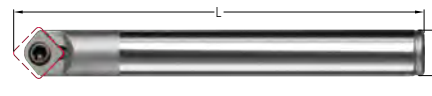

COD.	ØD [mm]	L [mm]	Vite (Inclusa)	Chiave (Inclusa)	Tipologia Inserti (Optional)
------	---------	--------	----------------	------------------	------------------------------

JOLLY B



STELI

SP1010-S	Ø10	90	SC30055	TORX-T8	SD08020CT-... SD080201W-...-
SP1010-L		150			

RICAMBI

SC30055	Vite Torx M3,0 H4x5,5 - 2,0Nm
TORX-T8	Chiave Torx T8

COD.	Rivestimento Inserto	Q [mm]	S [mm]	Re [mm]	H [mm]	Minimo Ordine
------	----------------------	--------	--------	---------	--------	---------------

INSERTI

SD08020CT-...

>> **MULTIFUNZIONE per:** Centrare, Svasare, Tornire, Sfacciare, Incidere, Scanalare e Smussare

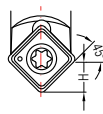
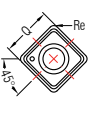

SD080208CT-D1	DEVIL (HV 3800 ±200)	8,3	2,38	0,8	4,9	10 pz.
SD080204CT-ZRN	ZRN (HV 2500 ±300)			0,4	5,3	10 pz.

SD080201W60-...

>> **IDEALE per:** Incidere e Scanalare a 60°

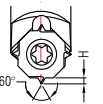
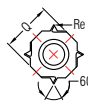

SD080201W60-D1	DEVIL (HV 3800 ±200)	8,3	2,38	0,1	0,95	4 pz.
SD080201W60-ZRN	ZRN (HV 2500 ±300)			0,1	0,95	4 pz.

SD080201W90-...

>> **IDEALE per:** Incidere e Scanalare a 90°

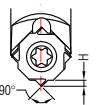
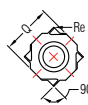

SD080201W90-D1	DEVIL (HV 3800 ±200)	8,3	2,38	0,1	0,95	4 pz.
SD080201W90-ZRN	ZRN (HV 2500 ±300)			0,1	0,95	4 pz.

RIVESTIMENTO INSERTI: DEVIL

KIT

RIVESTIMENTO INSERTI: ZRN

COD.
KS01 S CT D1

COD.
KS01 S U1 D1

COD.
KS01 S CT ZRN

COD.
KS01 S U1 ZRN



STELO	
1x SP1010-S	
INSERTI	VITI e CHIAVE
6x SD080208CT-D1	2x SC30055 1x TORX-T8

STELO	
1x SP1010-S	
INSERTI	VITI e CHIAVE
2x SD080208CT-D1 2x SD080201W60-D1 2x SD080201W90-D1	2x SC30055 1x TORX-T8

STELO	
1x SP1010-S	
INSERTI	VITI e CHIAVE
6x SD080204CT-ZRN	2x SC30055 1x TORX-T8

STELO	
1x SP1010-S	
INSERTI	VITI e CHIAVE
2x SD080204CT-ZRN 2x SD080201W60-ZRN 2x SD080201W90-ZRN	2x SC30055 1x TORX-T8

JOLLY B Ø16

MAX 16.000min⁻¹

- SP1614-S
- SP1614-L

Utensili multifunzionali bilanciati a singolo tagliente per centrare, svasare, tornire, sfacciare, incidere, scanalare, smussare e raggiare.

Ogni stelo viene fornito di:
1 Vite; 1 Chiave Torx.

In Optional:

inserti per varie tipologie di lavorazioni e materiali.

KIT Disponibili! (Stelo + Inserti)

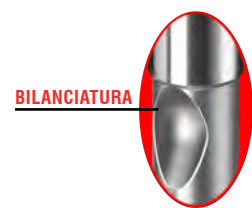
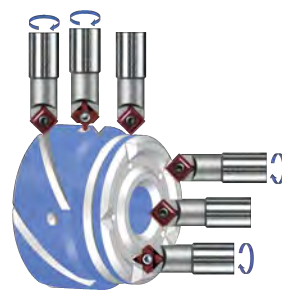
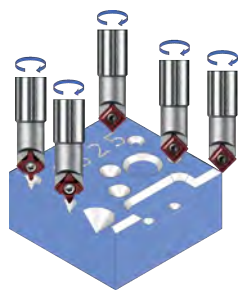

- SP1614-S
- SP1614-L

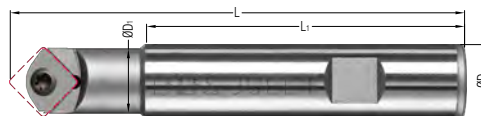

COD.	ØD [mm]	ØD ₁ [mm]	L [mm]	L ₁ [mm]	Vite (Inclusa)	Chiave (Inclusa)	Tipologia Inserti (Optional)
------	---------	----------------------	--------	---------------------	----------------	------------------	------------------------------

JOLLY B



STELI		ØD	ØD ₁	L	L ₁	Vite	Chiave	Tipologia Inserti
SP1614-S	Ø16	Ø14	100	70	SC35087	TORX-T15	SD11T30.CT... SD11T30.CTP60... SD11T30.CTD... SD11T308CTR... SD11T308CTD...	
SP1614-L			150	120				
SC35087	Vite Torx M3,5 H4x8,7 - 2,5Nm							
TORX-T15	Chiave Torx T15							

COD.	Rivestimento Inserto	Q [mm]	S [mm]	Re [mm]	ØD [mm]	R [mm]	H [mm]	X [mm]	Y [mm]	Minimo Ordine
------	----------------------	--------	--------	---------	---------	--------	--------	--------	--------	---------------

INSERTI

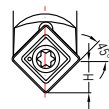
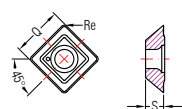

SD11T30.CT...		>> MULTIFUNZIONE per: Centrare, Svasare, Tornire, Sfacciare, Incidere, Scanalare e Smussare								
SD11T304CT-D1	DEVIL (HV 3800 ±200)	11	3,97	0,4	-	-	7,2	-	-	10 pz.
SD11T308CT-D1	DEVIL (HV 3800 ±200)	11	3,97	0,8	-	-	6,7	-	-	10 pz.
SD11T302CT-ZRN	ZRN (HV 2500 ±300)	11	3,97	0,2	-	-	7,4	-	-	10 pz.
SD11T304CT-ZRN	ZRN (HV 2500 ±300)	11	3,97	0,4	-	-	7,2	-	-	10 pz.

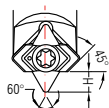
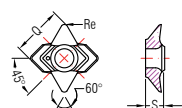

SD11T30.CTP60...		>> IDEALE per: Centrare, Scanalare a 60° e Smussare a 30° • Lavorazioni Secondarie: Tornire, Incidere a 60° e Smussare a 45°								
SD11T308CTP60-D1	DEVIL (HV 3800 ±200)	11	3,97	0,8	-	-	4,4	-	-	4 pz.
SD11T304CTP60-ZRN	ZRN (HV 2500 ±300)	11	3,97	0,4	-	-	4,75	-	-	4 pz.

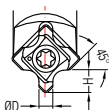
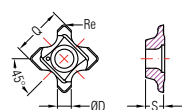

SD11T30.CTD...		>> IDEALE per: Fori da Centro Raggiati a 60° (Simile DIN 332 Forma R) • Lavorazioni Secondarie: Centrare, Tornire, Incidere e Smussare								
SD11T308CTD20-D1	DEVIL (HV 3800 ±200)	11	3,97	0,8	2,0	-	3,9	-	-	4 pz.
SD11T308CTD25-D1					2,5	-	4,3	-	-	4 pz.
SD11T308CTD315-D1					3,15	-	4,8	-	-	4 pz.
SD11T304CTD20-ZRN	ZRN (HV 2500 ±300)	11	3,97	0,4	2,0	-	3,9	-	-	4 pz.
SD11T304CTD25-ZRN					2,5	-	4,3	-	-	4 pz.
SD11T304CTD315-ZRN					3,15	-	4,8	-	-	4 pz.

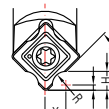
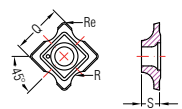

SD11T308CTR...		>> IDEALE per: Raggiare • Lavorazioni Secondarie: Centrare, Tornire, Incidere e Smussare								
SD11T308CTR10-D1	DEVIL (HV 3800 ±200)	11	3,97	0,8	-	1,0	2,5	2,5	1,5	4 pz.
SD11T308CTR15-D1					-	1,5	3,0	3,0	1,5	4 pz.
SD11T308CTR20-D1					-	2,0	3,5	3,5	1,5	4 pz.
SD11T308CTR25-D1					-	2,5	4,0	4,0	1,5	4 pz.
SD11T308CTR30-D1					-	3,0	4,15	4,5	1,15	4 pz.
SD11T308CTR10-ZRN	ZRN (HV 2500 ±300)	11	3,97	0,8	-	1,0	2,5	2,5	1,5	4 pz.
SD11T308CTR15-ZRN					-	1,5	3,0	3,0	1,5	4 pz.
SD11T308CTR20-ZRN					-	2,0	3,5	3,5	1,5	4 pz.
SD11T308CTR25-ZRN					-	2,5	4,0	4,0	1,5	4 pz.
SD11T308CTR30-ZRN					-	3,0	4,15	4,5	1,15	4 pz.

KIT JOLLY B Ø16

MAX 16.000min⁻¹

• KS02 S... (Stelo SP1614-S)

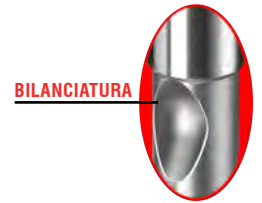
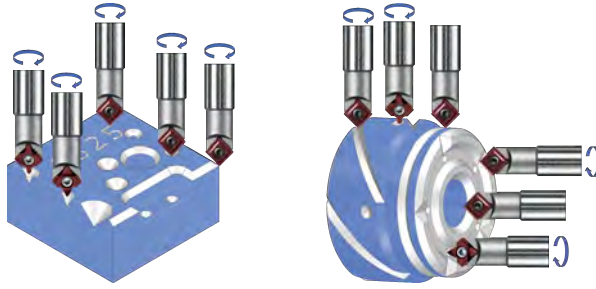

KIT utensile multifunzionale bilanciato a singolo tagliente per centrare, svasare, tornire, sfacciare, incidere, scanalare e smussare.

Ogni KIT viene fornito di:

- 1 Stelo
- 6 Inserti
- 2 Viti
- 1 Chiave Torx
- 1 Confezione

• SP1614-S

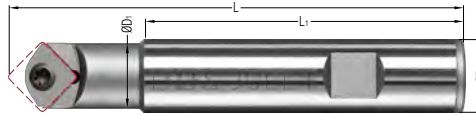

ØD [mm]	ØD1 [mm]	L [mm]	L1 [mm]
Ø16	Ø14	100	70

COD.	Rivestimento Inserto	Q [mm]	S [mm]	Re [mm]	ØD [mm]	H [mm]
------	----------------------	--------	--------	---------	---------	--------

INSERTI per KIT

SD11T30.CT... >> **MULTIFUNZIONE per:** Centrare, Svasare, Tornire, Sfacciare, Incidere, Scanalare e Smussare

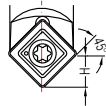
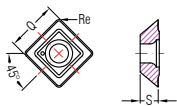

SD11T308CT-D1	DEVIL (HV 3800 ±200)	11	3,97	0,8	-	6,7
SD11T304CT-ZRN	ZRN (HV 2500 ±300)			0,4	-	7,2

SD11T30.CTP60... >> **IDEALE per:** Centrare, Scanalare a 60° e Smussare a 30° • **Lavorazioni Secondarie:** Tornire, Incidere a 60° e Smussare a 45°

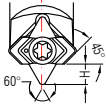
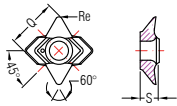

SD11T308CTP60-D1	DEVIL (HV 3800 ±200)	11	3,97	0,8	-	4,4
SD11T304CTP60-ZRN	ZRN (HV 2500 ±300)			0,4	-	4,75

SD11T30.CTD... >> **IDEALE per:** Fori da Centro Raggiati a 60° (Simile DIN 332 Forma R) • **Lavorazioni Secondarie:** Centrare, Tornire, Incidere e Smussare

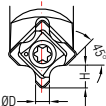
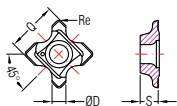

SD11T308CTD20-D1	DEVIL (HV 3800 ±200)	11	3,97	0,8	2,0	3,9
SD11T308CTD25-D1					2,5	4,3
SD11T308CTD315-D1					3,15	4,8
SD11T304CTD20-ZRN	ZRN (HV 2500 ±300)			0,4	2,0	3,9
SD11T304CTD25-ZRN					2,5	4,3
SD11T304CTD315-ZRN					3,15	4,8

RIVESTIMENTO INSERTI: DEVIL KIT RIVESTIMENTO INSERTI: ZRN

COD.
KS02 S CT D1

COD.
KS02 S U1 D1

COD.	
KS02 S CT ZRN04	178,00

COD.
KS02 S U1 ZRN04



STELO	
1x SP1614-S	
INSERTI	VITI e CHIAVE
6x SD11T308CT-D1	2x SC35087 1x TORX-T15

STELO	
1x SP1614-S	
INSERTI	VITI e CHIAVE
2x SD11T308CT-D1 1x SD11T308CTP60-D1 1x SD11T308CTD20-D1 1x SD11T308CTD25-D1 1x SD11T308CTD315-D1	2x SC35087 1x TORX-T15

STELO	
1x SP1614-S	
INSERTI	VITI e CHIAVE
6x SD11T304CT-ZRN	2x SC35087 1x TORX-T15

STELO	
1x SP1614-S	
INSERTI	VITI e CHIAVE
2x SD11T304CT-ZRN 1x SD11T304CTP60-ZRN 1x SD11T304CTD20-ZRN 1x SD11T304CTD25-ZRN 1x SD11T304CTD315-ZRN	2x SC35087 1x TORX-T15

I DATI INDICATI NON SONO IMPEGNATIVI E POSSONO ESSERE MODIFICATI ANCHE SENZA PREAVVISO.

JOLLY B Ø20

120°
142°

- SP2017-120D-S (120°)
- SP2018-142D-S (142°)

Utensili multifunzionali bilanciati a singolo tagliente per centrare, svasare e smussare.

Ogni stelo viene fornito di:
1 Vite; 1 Chiave Torx.

In Optional:
inserti per varie tipologie di lavorazioni e materiali.

KIT Disponibili! (Stelo + Inserti)

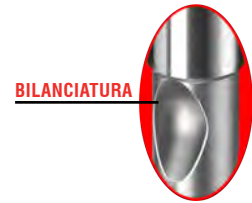
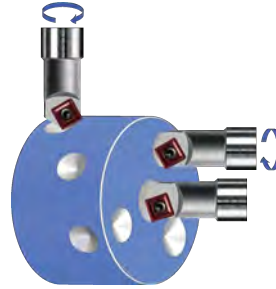
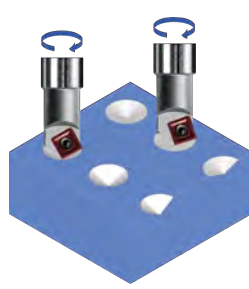

• SP2017-120D-S (120°)

• SP2018-142D-S (142°)

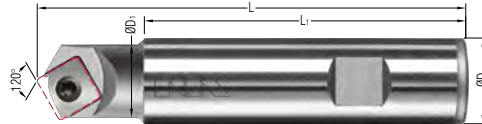

COD.	ØD [mm]	ØD ₁ [mm]	L [mm]	L ₁ [mm]	Vite (Inclusa)	Chiave (Inclusa)	Tipologia Inserti (Optional)
------	---------	----------------------	--------	---------------------	----------------	------------------	------------------------------

JOLLY B

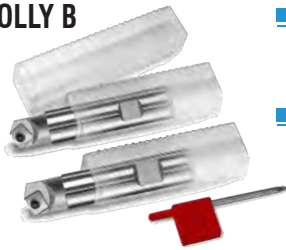

STELI		COD.	ØD [mm]	ØD ₁ [mm]	L [mm]	L ₁ [mm]	Vite (Inclusa)	Chiave (Inclusa)	Tipologia Inserti (Optional)
		SP2017-120D-S	Ø20	Ø17	100	75	SC35087	TORX-T15	SD11T30.CT-...
		SP2018-142D-S		Ø18.7					
		SC35087	Vite Torx M3,5 H4x8,7 - 2,5Nm						
		TORX-T15	Chiave Torx T15						

COD.	RIVESTIMENTO INSERTO	Q [mm]	S [mm]	Re [mm]	STELO	α [mm]	H [mm]	Minimo Ordine
------	----------------------	--------	--------	---------	-------	--------	--------	---------------

INSERTI

SD11T30.CT-... >> **IDEALE per:** Centrare e Svasare a 120° o 142°, e Smussare a 60° o 71°

COD.	RIVESTIMENTO INSERTO	Q [mm]	S [mm]	Re [mm]	STELO	α [mm]	H [mm]	Minimo Ordine
SD11T304CT-D1	DEVIL (HV 3800 ±200)	11	3,97	0,4	SP2017-120D-S	120°	5,1	10 pz.
					SP2018-142D-S	142°	3,3	
SD11T308CT-D1	DEVIL (HV 3800 ±200)	11	3,97	0,8	SP2017-120D-S	120°	4,75	10 pz.
					SP2018-142D-S	142°	3,05	
SD11T302CT-ZRN	ZRN (HV 2500 ±300)	11	3,97	0,2	SP2017-120D-S	120°	5,3	10 pz.
					SP2018-142D-S	142°	3,4	
SD11T304CT-ZRN	ZRN (HV 2500 ±300)	11	3,97	0,4	SP2017-120D-S	120°	5,1	10 pz.
					SP2018-142D-S	142°	3,3	

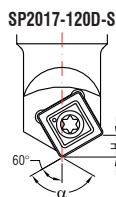

RIVESTIMENTO INSERTI: DEVIL

KIT

RIVESTIMENTO INSERTI: ZRN

COD.
KS06 S CT D1

COD.
KS07 S CT D1

COD.
KS06 S CT ZRN04

COD.
KS07 S CT ZRN04



STELO	
1x SP2017-120D-S	
INSERTI	VITI e CHIAVE
6x SD11T308CT-D1	2x SC35087 1x TORX-T15

STELO	
1x SP2018-142D-S	
INSERTI	VITI e CHIAVE
6x SD11T308CT-D1	2x SC35087 1x TORX-T15

STELO	
1x SP2017-120D-S	
INSERTI	VITI e CHIAVE
6x SD11T304CT-ZRN	2x SC35087 1x TORX-T15

STELO	
1x SP2018-142D-S	
INSERTI	VITI e CHIAVE
6x SD11T304CT-ZRN	2x SC35087 1x TORX-T15

SP12-Z4-05-1219

SP1625R-S

SP16-Z1-11-1328

SP2017-18-S

SP20-Z4-11-2740

SP2020-28-S

SP20-Z4-11-2740-M12

Ra ≤

Ra ≤ 0,4 μm

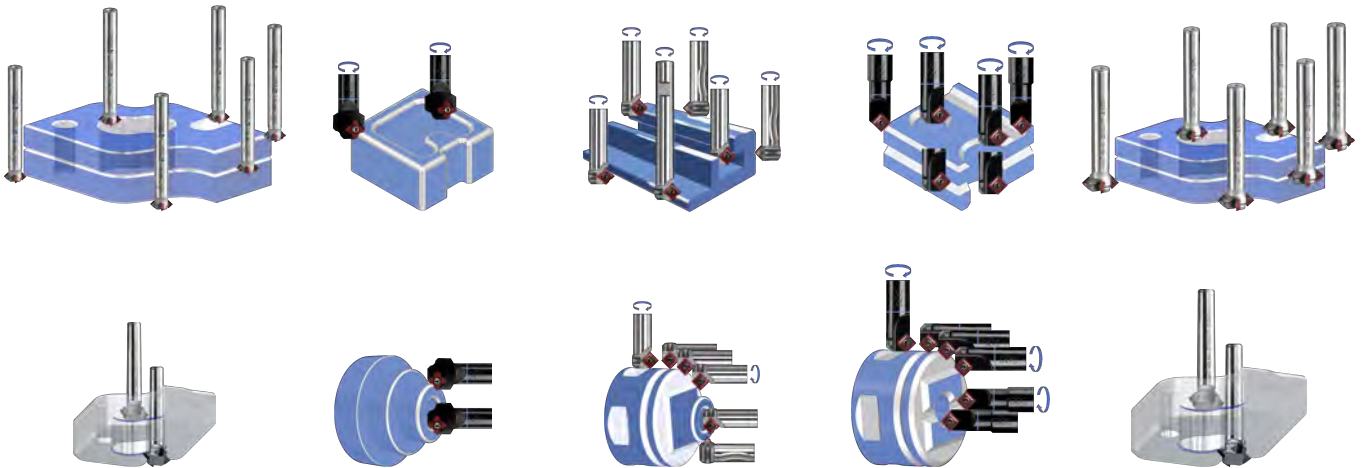

I DATI INDICATI NON SONO IMPEGNATIVI E POSSONO ESSERE MODIFICATI ANCHE SENZA PREAVVISO.

SCELTA DELL'INSERTO E SUE APPLICAZIONI

MODELLO STELO	TIPO DI LAVORAZIONE	ANGOLO	MATERIALE DA LAVORARE		RIVESTIMENTO						
			ACCIAI LEGATI e INOX LEGATI ACCIAI AL CARBONIO GHISE MEEHANITE	ACCIAIO INOX ALLUMINIO LEGHE NON FERROSE							
	FRESARE	SVASARE	TORNIRE	SFACCIARE	SMUSSARE	SOTTOQUADRA	RAGGIARE	RAGGIARE SOTTOQUADRA	90°	MODELLO/TIPOLOGIA INSERTO	-D1 (DEVIL) -...= -ZRN
SP12-Z4-05-1219	●	(2)			●	●			●	◆ SD050203-... ◆ SD050203R05-... ◆ SD050203R075-... ◆ SD050203R10-...	
SP1625R-S			(2)			(1)			●	◆ SD11T30-... ◆ SD11T308R10-... ◆ SD11T308R15-... ◆ SD11T308R20-... ◆ SD11T308R25-... ◆ SD11T308R30-...	
SP16-Z1-11-1328	●				●	●			●	◆ SD11T30-... ◆ SD11T308R10-... ◆ SD11T308R15-... ◆ SD11T308R20-... ◆ SD11T308R25-... ◆ SD11T308R30-...	
SP20-Z4-11-2740	●				●	●			●	◆ SD11T30-... ◆ SD11T308R10-... ◆ SD11T308R15-... ◆ SD11T308R20-... ◆ SD11T308R25-... ◆ SD11T308R30-...	
SP20-Z4-11-2740-M12	(2)				(2)	(2)	(1)		●	◆ SD11T30-... ◆ SD11T308R10-... ◆ SD11T308R15-... ◆ SD11T308R20-... ◆ SD11T308R25-... ◆ SD11T308R30-...	
SP2017-18-S		(2)	(2)	(2)	(1)				●	◆ SD11T30-...	
SP2020-28-S	(2)	(2)	(2)	(1)	(1)				●	◆ SD11T30-...	

(1) Lavorazioni ideali; (2)(3) Lavorazioni secondarie

JOLLY Z4 Ø12

MAX 20.000min⁻¹

•SP12-Z4-05-1219

Ra ≤ 0,4μm

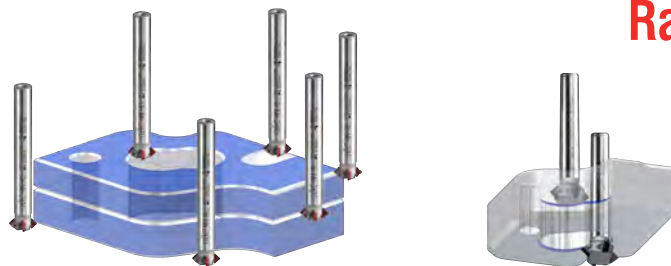

•SP12-Z4-05-1219



Mini-Frese per lavorazioni di finitura a quattro taglianti per fresare, smussare e raggiare anche sottosquadra.

Ogni fresa viene fornita di:
4 Viti; 1 Chiave Torx.

In Optional:

inserti per varie tipologie di lavorazioni e materiali.

KIT Disponibili! (Stelo + Inserti)

I DATI INDICATI NON SONO IMPEGNATIVI E POSSONO ESSERE MODIFICATI ANCHE SENZA PREAVVISO.

COD.	ØD [mm]	L [mm]	Vite (Inclusa)	Chiave (Inclusa)	Tipologia Inserti (Optional)
------	---------	--------	----------------	------------------	------------------------------

JOLLY Z4



STELI

SP12-Z4-05-1219	Ø12	100	SC20048	TORX-T6	SD050203-... SD050203R-...
-----------------	-----	-----	---------	---------	-------------------------------

RICAMBI

SC20048	Vite Torx M2,0x4,8 - 0,8Nm				
TORX-T6	Chiave Torx T6				

COD.	Rivestimento Inserto	Q [mm]	S [mm]	Re [mm]	R [mm]	A [mm]	H [mm]	X [mm]	Y [mm]	Minimo Ordine
------	----------------------	--------	--------	---------	--------	--------	--------	--------	--------	---------------

INSERTI

SD050202-... >> IDEALE per: Fresare e Smussare (anche Sottosquadra)

SD050203-D1	DEVIL (HV 3800 ±200)	5,3	2	0,3	-	5,8	3,3	-	-	10 pz.
SD050203-ZRN	ZRN (HV 2500 ±300)			0,3	-	5,8	3,3	-	-	10 pz.

SD050202R-... >> IDEALE per: Raggiare (anche Sottosquadra) • Lavorazioni Secondarie: Fresare e Smussare (anche Sottosquadra)

SD050203R05-D1	DEVIL (HV 3800 ±200)	5,3	2	0,5	-	-	-	7,95	1,4	4 pz.
SD050203R075-D1				0,3	0,75	5,8	-	8,05	1,27	4 pz.
SD050203R10-D1				1,0	-	-	8,2	1,15	4 pz.	
SD050203R05-ZRN	ZRN (HV 2500 ±300)	5,3	2	0,5	-	-	-	7,95	1,4	4 pz.
SD050203R075-ZRN				0,3	0,75	5,8	-	8,05	1,27	4 pz.
SD050203R10-ZRN				1,0	-	-	8,2	1,15	4 pz.	

RIVESTIMENTO INSERTI: DEVIL

KIT

RIVESTIMENTO INSERTI: ZRN

COD.
KS12 Z4 03 D1

COD. (*RAGGIO A SCELTA)			
KS12 Z4 R(*R) D1			
(*R)	05	075	10
R	0,5	0,75	1,0

COD.
KS12 Z4 03 ZRN

COD. (*RAGGIO A SCELTA)			
KS12 Z4 R(*R) ZRN			
(*R)	05	075	10
R	0,5	0,75	1,0



STELO	
1x SP12-Z4-05-1219	
INSERTI	VITI e CHIAVE
4x SD050203-D1	5x SC20048 1x TORX-T6

STELO	
1x SP12-Z4-05-1219	
INSERTI	VITI e CHIAVE
4x SD050203R(*R)-D1	5x SC20048 1x TORX-T6

STELO	
1x SP12-Z4-05-1219	
INSERTI	VITI e CHIAVE
4x SD050203-ZRN	5x SC20048 1x TORX-T6

STELO	
1x SP12-Z4-05-1219	
INSERTI	VITI e CHIAVE
4x SD050203R(*R)-ZRN	5x SC20048 1x TORX-T6

JOLLY Ø16

• SP1625R-S

Utensili multifunzionali a singolo tagliante per tornire, smussare e raggiare.

Ogni stelo viene fornito di:
1 Vite; 1 Chiave Torx.

In Optional:
inserti per varie tipologie di lavorazioni e materiali.

KIT Disponibili! (Stelo + Inserti)

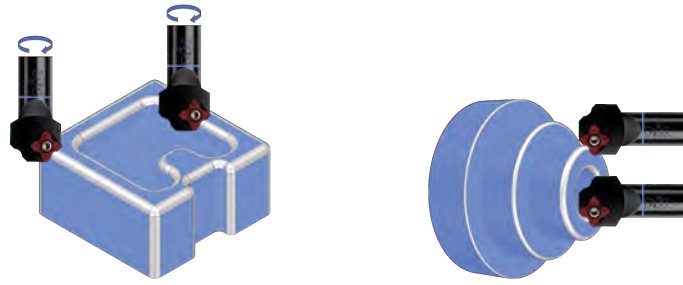

SP1625R-S



COD.	ØD [mm]	ØD ₁ [mm]	L [mm]	L ₁ [mm]	Vite (Inclusa)	Chiave (Inclusa)	Tipologia Inserti (Optional)
------	---------	----------------------	--------	---------------------	----------------	------------------	------------------------------

JOLLY



STELI

SP1625R-S	Ø16	Ø24	100	80	SC35087	TORX-T15	SD11T30-... SD11T308R-....
-----------	-----	-----	-----	----	---------	----------	-------------------------------

RICAMBI

SC35087	Vite Torx M3,5 H4x8,7 - 2,5Nm
TORX-T15	Chiave Torx T15

COD.	Rivestimento Inserto	Q [mm]	S [mm]	Re [mm]	R [mm]	A [mm]	H [mm]	X [mm]	Y [mm]	Minimo Ordine
------	----------------------	--------	--------	---------	--------	--------	--------	--------	--------	---------------

INSERTI

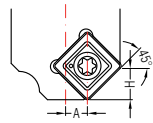
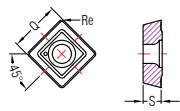

SD11T30-...

>> **IDEALE per:** Smussare • **Lavorazioni Secondarie:** Tornire

SD11T308-D1	DEVIL (HV 3800 ±200)	11	3,97	0,8	-	4,8	6,85	-	-	10 pz.
SD11T303-ZRN	ZRN (HV 2500 ±300)			0,3	-	4,8	7,4	-	-	10 pz.

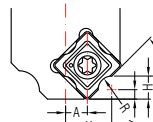
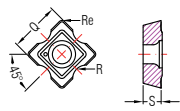

SD11T308R-....

>> **IDEALE per:** Raggiare • **Lavorazioni Secondarie:** Tornire e Smussare

SD11T308R10-D1	DEVIL (HV 3800 ±200)	11	3,97	1,0	-	9,25	3,0	4 pz.	
SD11T308R15-D1				1,5	-	9,5	2,83	4 pz.	
SD11T308R20-D1				2,0	6,35	-	9,75	2,52	4 pz.
SD11T308R25-D1				2,5	-	10,0	2,27	4 pz.	
SD11T308R30-D1				3,0	-	10,25	2,1	4 pz.	
SD11T308R10-ZRN	ZRN (HV 2500 ±300)	11	3,97	1,0	-	9,25	3,0	4 pz.	
SD11T308R15-ZRN				1,5	-	9,5	2,83	4 pz.	
SD11T308R20-ZRN				2,0	6,35	-	9,75	2,52	4 pz.
SD11T308R25-ZRN				2,5	-	10,0	2,27	4 pz.	
SD11T308R30-ZRN				3,0	-	10,25	2,1	4 pz.	

RIVESTIMENTO INSERTI: DEVIL

KIT

RIVESTIMENTO INSERTI: ZRN

COD.
KS08 S T3 D1

COD. (*RAGGIO A SCELTA)
KS08 S R(*R) D1

(*R)	10	15	20	25	30
R	1,0	1,5	2,0	2,5	3,0

COD.
KS08 S T3 ZRN

COD. (*RAGGIO A SCELTA)
KS08 S R(*R) ZRN

(*R)	10	15	20	25	30
R	1,0	1,5	2,0	2,5	3,0



STELO	
1x SP1625R-S	
INSERTI	VITI e CHIAVE
4x SD11T308-D1	2x SC35087 1x TORX-T15

STELO	
1x SP1625R-S	
INSERTI	VITI e CHIAVE
4x SD11T308R(*R)-D1	2x SC35087 1x TORX-T15

STELO	
1x SP1625R-S	
INSERTI	VITI e CHIAVE
4x SD11T303-ZRN	2x SC35087 1x TORX-T15

STELO	
1x SP1625R-S	
INSERTI	VITI e CHIAVE
4x SD11T308R(*R)-ZRN	2x SC35087 1x TORX-T15

JOLLY Z1 Ø16

MAX 15.000min⁻¹

•SP16-Z1-11-1328

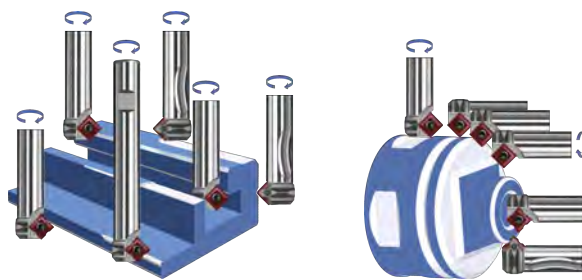

Mini-Frese per lavorazioni di finitura a singolo tagliente per fresare, svasare, tornire, smussare e raggiare anche sottosquadra.

Ogni fresa viene fornita di:
1 Vite; 1 Chiave Torx.

In Optional:
inserti per varie tipologie di lavorazioni e materiali.

KIT Disponibili! (Stelo + Inserti)

•SP16-Z1-11-1328

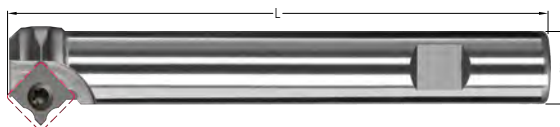

JOLLY Z1



STELI

COD.	ØD [mm]	L [mm]	Vite (Inclusa)	Chiave (Inclusa)	Tipologia Inserti (Optional)
SP16-Z1-11-1328	Ø16	120	SC35087	TORX-T15	SD11T30-... SD11T308R-...

RICAMBI

SC35087	Vite Torx M3,5 H4x8,7 - 2,5Nm
TORX-T15	Chiave Torx T15

INSERTI

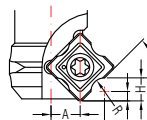
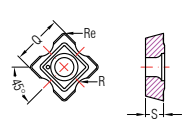
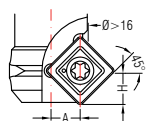
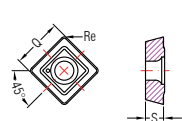

SD11T30-... >> **IDEALE per:** Fresare, Svasare, Tornire e Smussare (anche Sottosquadra)

COD.	Rivestimento Inserto	Q [mm]	S [mm]	Re [mm]	R [mm]	A [mm]	H [mm]	X [mm]	Y [mm]	Minimo Ordine
SD11T308-D1	DEVIL (HV 3800 ±200)	11	3,97	0,8	-	6,35	6,85	-	-	10 pz.
SD11T303-ZRN	ZRN (HV 2500 ±300)			0,3	-	6,35	7,4	-	-	10 pz.

SD11T308R-... >> **IDEALE per:** Raggiare (anche Sottosquadra) • **Lavorazioni Secondarie:** Fresare, Tornire e Smussare (anche Sottosquadra)

SD11T308R10-D1	DEVIL (HV 3800 ±200)	11	3,97	1,0	-	10,75	3,0	4 pz.	
SD11T308R15-D1				1,5	-	11,0	2,83	4 pz.	
SD11T308R20-D1				2,0	6,35	-	11,25	2,52	4 pz.
SD11T308R25-D1				2,5	-	11,5	2,27	4 pz.	
SD11T308R30-D1				3,0	-	11,75	2,1	4 pz.	
SD11T308R10-ZRN	ZRN (HV 2500 ±300)	11	3,97	1,0	-	10,75	3,0	4 pz.	
SD11T308R15-ZRN				1,5	-	11,0	2,83	4 pz.	
SD11T308R20-ZRN				2,0	6,35	-	11,25	2,52	4 pz.
SD11T308R25-ZRN				2,5	-	11,5	2,27	4 pz.	
SD11T308R30-ZRN				3,0	-	11,75	2,1	4 pz.	

RIVESTIMENTO INSERTI: DEVIL

KIT

RIVESTIMENTO INSERTI: ZRN

COD.
KS16 Z1 T3 D1

COD. (*RAGGIO A SCELTA)					
KS16 Z1 R(*R) D1					
(*R)	10	15	20	25	30
R	1,0	1,5	2,0	2,5	3,0

COD.
KS16 Z1 T3 ZRN

COD. (*RAGGIO A SCELTA)					
KS16 Z1 R(*R) ZRN					
(*R)	10	15	20	25	30
R	1,0	1,5	2,0	2,5	3,0



STELO	
1x SP16-Z1-11-1328	
INSERTI	VITI e CHIAVE
4x SD11T308-D1	2x SC35087 1x TORX-T15

STELO	
1x SP16-Z1-11-1328	
INSERTI	VITI e CHIAVE
4x SD11T308R(*R)-D1	2x SC35087 1x TORX-T15

STELO	
1x SP16-Z1-11-1328	
INSERTI	VITI e CHIAVE
4x SD11T303-ZRN	2x SC35087 1x TORX-T15

STELO	
1x SP16-Z1-11-1328	
INSERTI	VITI e CHIAVE
4x SD11T308R(*R)-ZRN	2x SC35087 1x TORX-T15

JOLLY Z4 Ø20

MAX 15.000min⁻¹

- SP20-Z4-11-2740
- SP20-Z4-11-2740-M12

Mini-Frese per lavorazioni di finitura a quattro taglienti per fresare, smussare e raggiare anche sottosquadra.

Ogni fresa viene fornita di:
4 Viti; 1 Chiave Torx.

In Optional:

inserti per varie tipologie di lavorazioni e materiali.

KIT Disponibili! (Stelo + Inserti)

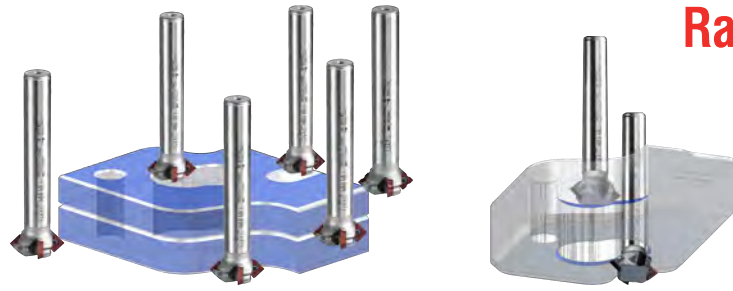

Ra ≤ 0,4µm

• SP20-Z4-11-2740



• SP20-Z4-11-2740-M12

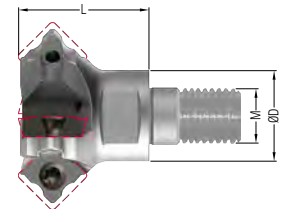

COD.	ØD [mm]	M	L [mm]	Vite (Inclusa)	Chiave (Inclusa)	Tipologia Inserti (Optional)
------	---------	---	--------	----------------	------------------	------------------------------

JOLLY Z4



STELI

SP20-Z4-11-2740	Ø20	-	140	SC35087	TORX-T15	SD11T30-... SD11T308R-......
SP20-Z4-11-2740-M12		M12	28			

RICAMBI

SC35087	Vite Torx M3,5 H4x8,7 - 2,5Nm
TORX-T15	Chiave Torx T15

COD.	Rivestimento Inserto	Q [mm]	S [mm]	Re [mm]	R [mm]	A [mm]	H [mm]	X [mm]	Y [mm]	Minimo Ordine
------	----------------------	--------	--------	---------	--------	--------	--------	--------	--------	---------------

INSERTI

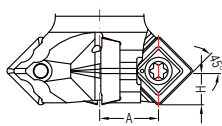
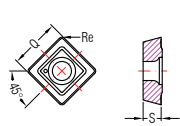

SD11T30-...

>> **IDEALE per:** Fresare e Smussare (anche Sottosquadra)

SD11T308-D1	DEVIL (HV 3800 ±200)	11	3,97	0,8	-	12,95	6,85	-	-	10 pz.
SD11T303-ZRN	ZRN (HV 2500 ±300)			0,3	-	12,95	7,4	-	-	10 pz.

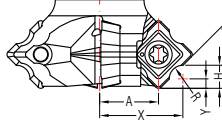
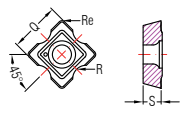

SD11T308R-...

>> **IDEALE per:** Raggiare (anche Sottosquadra) • **Lavorazioni Secondarie:** Fresare e Smussare (anche Sottosquadra)

SD11T308R10-D1	DEVIL (HV 3800 ±200)	11	3,97	1,0	-	17,3	3,0	-	-	4 pz.	
SD11T308R15-D1				1,5	-	17,55	2,83	-	-	4 pz.	
SD11T308R20-D1				2,0	12,95	-	17,8	2,52	-	-	4 pz.
SD11T308R25-D1				2,5	-	18,05	2,27	-	-	-	4 pz.
SD11T308R30-D1				3,0	-	18,3	2,1	-	-	-	4 pz.
SD11T308R10-ZRN	ZRN (HV 2500 ±300)	11	3,97	1,0	-	17,3	3,0	-	-	4 pz.	
SD11T308R15-ZRN				1,5	-	17,55	2,83	-	-	4 pz.	
SD11T308R20-ZRN				2,0	12,95	-	17,8	2,52	-	-	4 pz.
SD11T308R25-ZRN				2,5	-	18,05	2,27	-	-	-	4 pz.
SD11T308R30-ZRN				3,0	-	18,3	2,1	-	-	-	4 pz.

RIVESTIMENTO INSERTI: DEVIL

KIT

RIVESTIMENTO INSERTI: ZRN

COD.
KS20 Z4 T3 D1

COD. (*RAGGIO A SCELTA)					
KS20 Z4 R(*R) D1					
(*R)	10	15	20	25	30
R	1,0	1,5	2,0	2,5	3,0

COD.
KS20 Z4 T3 ZRN

COD. (*RAGGIO A SCELTA)					
KS20 Z4 R(*R) ZRN					
(*R)	10	15	20	25	30
R	1,0	1,5	2,0	2,5	3,0



STELO	
1x SP20-Z4-11-2740	
INSERTI	VITI e CHIAVE
4x SD11T308-D1	5x SC35087 1x TORX-T15



STELO	
1x SP20-Z4-11-2740	
INSERTI	VITI e CHIAVE
4x SD11T308R(*R)-D1	5x SC35087 1x TORX-T15



STELO	
1x SP20-Z4-11-2740	
INSERTI	VITI e CHIAVE
4x SD11T303-ZRN	5x SC35087 1x TORX-T15



STELO	
1x SP20-Z4-11-2740	
INSERTI	VITI e CHIAVE
4x SD11T308R(*R)-ZRN	5x SC35087 1x TORX-T15

JOLLY Ø20

- SP2017-18-S
- SP2020-28-S

Utensili multifunzionali a singolo tagliente per svasare, tornire, sfacciare e smussare anche sottosquadra (solo SP2020-28-S). Ogni stelo viene fornito di:

1 Vite; 1 Chiave Torx.
In Optional:
inserti per varie tipologie di lavorazioni e materiali.

KIT Disponibili! (Stelo + Inserti)

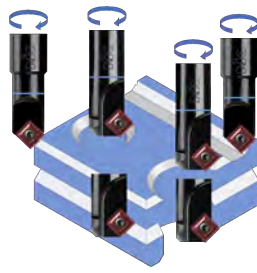

• SP2017-18-S

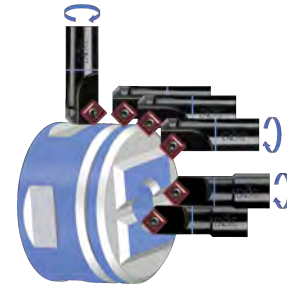

• SP2020-28-S



COD.	ØD [mm]	ØD ₁ [mm]	L [mm]	L ₁ [mm]	Vite (Inclusa)	Chiave (Inclusa)	Tipologia Inserti (Optional)
------	---------	----------------------	--------	---------------------	----------------	------------------	------------------------------

JOLLY



STELI		COD.	ØD [mm]	ØD ₁ [mm]	L [mm]	L ₁ [mm]	Vite (Inclusa)	Chiave (Inclusa)	Tipologia Inserti (Optional)
		SP2017-18-S	Ø20	Ø17	120	80	SC35087	TORX-T15	SD11T30-...
		SP2020-28-S	Ø20	-	-	-	-	-	-
RICAMBI		SC35087	Vite Torx M3,5 H4x8,7 - 2,5Nm						
		TORX-T15	Chiave Torx T15						

COD.	RIVESTIMENTO INSERTO	Q [mm]	S [mm]	Re [mm]	STELO	A [mm]	H [mm]	Minimo Ordine
------	----------------------	--------	--------	---------	-------	--------	--------	---------------

INSERTI

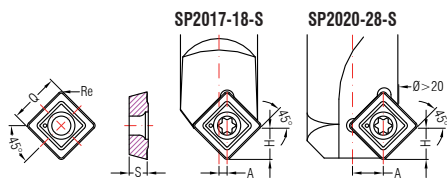

>> **IDEALE per:** Smussare (anche Sottosquadra con SP2020-28-S) • **Lavorazioni Secondarie:** Svasare, Tornire e Sfacciare

SD11T308-D1	DEVIL (HV 3800 ±200)	11	3,97	0,8	SP2017-18-S	1,3	6,7	10 pz.
				0,3	SP2020-28-S	6,5	6,85	
SD11T303-ZRN	ZRN (HV 2500 ±300)	11	3,97	0,8	SP2017-18-S	1,3	7,3	10 pz.
				0,3	SP2020-28-S	6,5	7,4	

RIVESTIMENTO INSERTI: DEVIL

KIT

RIVESTIMENTO INSERTI: ZRN

COD.	CONTENUTO
KS04 S T3 D1	1x SP2017-18-S



STELO	INSERTI	VITI e CHIAVE
1x SP2017-18-S	4x SD11T308-D1	2x SC35087 1x TORX-T15

COD.	CONTENUTO
KS05 S T3 D1	1x SP2020-28-S



STELO	INSERTI	VITI e CHIAVE
1x SP2020-28-S	4x SD11T308-D1	2x SC35087 1x TORX-T15

COD.	CONTENUTO
KS04 S T3 ZRN	1x SP2017-18-S



STELO	INSERTI	VITI e CHIAVE
1x SP2017-18-S	4x SD11T303-ZRN	2x SC35087 1x TORX-T15

COD.	CONTENUTO
KS05 S T3 ZRN	1x SP2020-28-S



STELO	INSERTI	VITI e CHIAVE
1x SP2020-28-S	4x SD11T303-ZRN	2x SC35087 1x TORX-T15

NIC S.r.l.

EUROPEAN INDUSTRIAL COMPONENTS

Oltre 20 anni di qualità in tutto il mondo!



EUROPEAN INDUSTRIAL COMPONENTS

NIK by SINERGY S.N.C.
VIA MARTIRI DELLA LIBERTA', 106
30038 SPINEA (VENEZIA) ITALY
Tel.: +39-041-86283800
Fax: +39-041-86283801
www.sinergya.eu
E-Mail: info@sinergya.eu