



SINERGYA

HNBJ Boring System G2.5 12000rpm

“PROMO 2024” HNBJ16

KIT COMPLETO PER ALESATURA FORI DA Ø6 A Ø51 mm

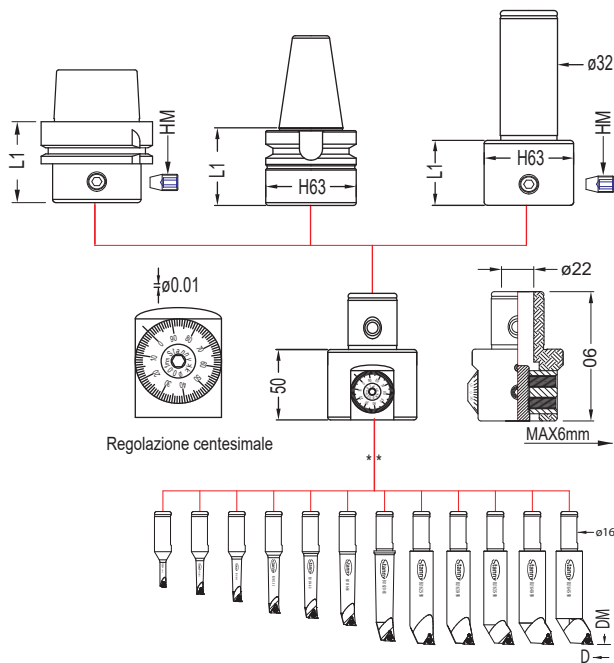

Order No.	Model	Taper Shank	L1	N.W	EUR
P2416910410	NT40-HNBJ16	DIN2080 ISO40-H63-60	55	2.60	1400,00
P2416911410	BT40-HNBJ16	MAS403 BT40-H63-55	55	2.44	
P2416912410	SK40-HNBJ16	DIN69871A ISO40-H63-60	60	2.43	
P2416323210	C32-H63-HNBJ16	C32-H63-55	55	2.61	
P2416910510	NT50-HNBJ16	DIN2080 ISO50-H63-65	65	4.70	1750,00
P2416911510	BT50-HNBJ16	MAS403 BT50-H63-65	65	5.00	
P2416912510	SK50-HNBJ16	DIN69871A ISO50-H63-65	65	4.70	
P2416914610	HSK63-HNBJ16	DIN69893A HSK63-H63-67	67	2.36	

* Vedi pag. 20-25-126 catalogo originale Stanny 2022.

** TOOL ZOOM, possibilità di inserire steli in HM D.16 per fori profondi. Vedi pag. 124.

Order No.	Model	Boring Range øDMin-øDMax	DM	Insert	Bolt	Wrench	N.W
16010624	BJ1606-24	6-9	24	WBG0601..L	SB-1STR-M2	T6	0.08
16010832	BJ1608-32	8-11	32	TBGT0601..L			0.08
16011040	BJ1610-40	10-13	40	TPGH0902..L			0.08
16011253	BJ1612-53	12-15	53		0.10		
16011460	BJ1614-60	14-17	60		0.10		
16011668	BJ1616-68	16-21	68		0.12		
16012083	BJ1620-83	20-26	83	TPGH1103..L	SB-3TR-M3	T8	0.20
16012590	BJ1625-90	25-31	90				0.30
16013090	BJ1630-90	30-36	90				0.32
16013590	BJ1635-90	35-41	90				0.32
16014090	BJ1640-90	40-46	90				0.38
16014590	BJ1645-90	45-51	90				0.38

*Vedi pag. 87 catalogo originale Stanny 2022.



Via Martiri della Libertà, 106 - 30038 - Spinea VE
Tel +39 041 8628380 - Fax +39 041 8628381

info@sinergya.eu
www.sinergya.eu

HNBJ16/04-2024