





SONDER-WERKZEUGHALTER



SPECIAL TOOLHOLDERS



СПЕЦИАЛЬНЫЕ РЕЗЦЕДЕРЖАТЕЛИ



PORTEOUTILS SPECIAUX



PORTAUTENSILI SPECIALI



专用刀柄



DMG MORI

PORTAUTENSILI DMG MORI

Pag. 384-400

OKUMA TOOLHOLDERS

PORTAUTENSILI OKUMA

Pag. 401-413

NAKAMURA TOME TOOLHOLDERS

PORTAUTENSILI NAKAMURA

Pag. 414-417

DOOSAN PUMA TOOLHOLDERS - BMT 45 /55/65/75

PORTAUTENSILI DEWOO PUMA

Pag. 418-423

MAZAK TOOLHOLDERS

PORTAUTENSILI MAZAK

Pag. 424-426

WFL TOOLHOLDERS

PORTAUTENSILI WFL

Pag. 427

GOODWAY TOOLHOLDERS

PORTAUTENSILI GOODWAY

Pag. 428

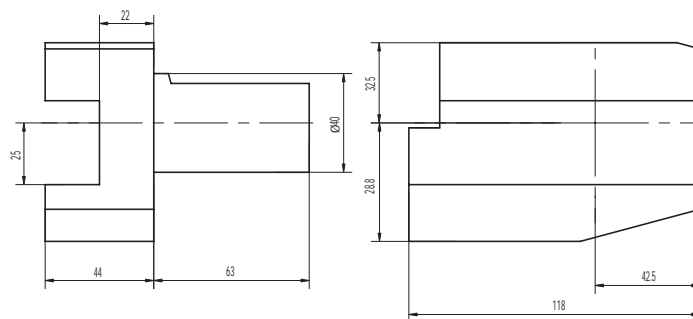
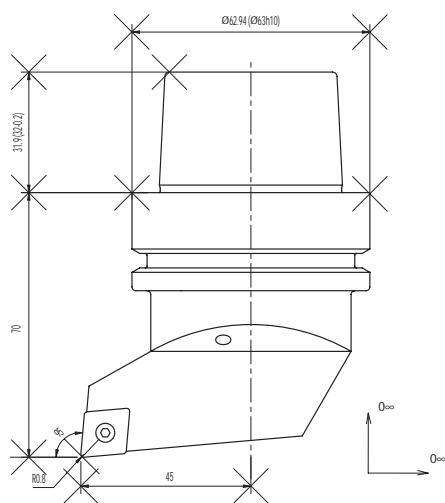
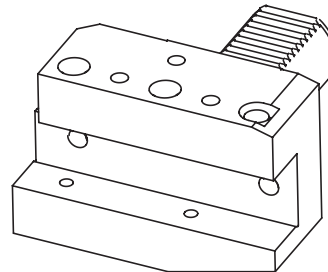
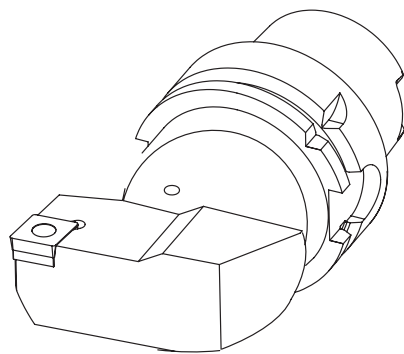

Auf Anfrage sind Dispositionszeichnungen im dxf Format mit entsprechenden Massen verfügbar.



On request we can send you general layouts in dxf format with the relative dimensions.



По запросу мы готовы выслать Вам общий чертеж в формате dxf с соответствующими размерами.



Sur demande les dessins d'avant-projet en format dxf sont disponibles avec les relatives cotes.



Sono disponibili a richiesta i disegni di massima in formato dxf con relative quote di ingombro.



如有要求，我们可以发送DXF格式的带有相关参数的总体设计。

DMG MORI (VDI30)

CTX 210/310/410 V3/V1 - CTX 320/420 V3
 CTX Alpha 300/500 V3
 CTX Beta 500/800/1250 V3 (option)
 CTV 160

AXIAL TURRET

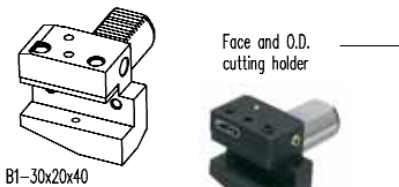

Face and O.D. cutting holder

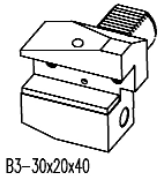

Face and O.D. cutting holder overhead

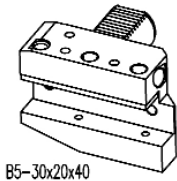

Face and O.D. cutting holder

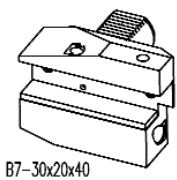

Face and O.D. cutting holder overhead

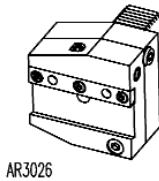

Cut-off holder
26 mm

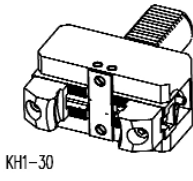

Bar puller

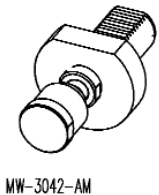

VDI damped, adjustable, stop bar

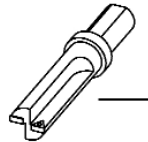
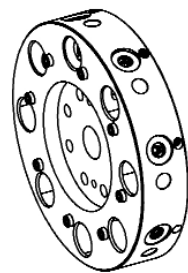

Qualified tool
20x20 mm

ACCESSORIES



Boring bar sleeve $\varnothing 25$ mm

- 115-62574 ($\varnothing 8$ mm)
- 115-62575 ($\varnothing 10$ mm)
- 115-62576 ($\varnothing 12$ mm)
- 115-62577 ($\varnothing 16$ mm)
- 115-62578 ($\varnothing 20$ mm)

Boring bar sleeve $\varnothing 32$ mm

- 165-63223 ($\varnothing 8$ mm)
- 165-63224 ($\varnothing 10$ mm)
- 165-63225 ($\varnothing 12$ mm)
- 165-63226 ($\varnothing 16$ mm)
- 165-63227 ($\varnothing 20$ mm)
- 165-63228 ($\varnothing 25$ mm)

Boring bar sleeve $\varnothing 40$ mm

- 165-64075 ($\varnothing 8$ mm)
- 165-64076 ($\varnothing 10$ mm)
- 165-64077 ($\varnothing 12$ mm)
- 165-64078 ($\varnothing 16$ mm)
- 165-64079 ($\varnothing 20$ mm)
- 165-64080 ($\varnothing 25$ mm)
- 165-64081 ($\varnothing 32$ mm)

Toolholder for insert drill

- E1-30x06WN ($\varnothing 6$ mm)
- E1-30x08WN ($\varnothing 8$ mm)
- E1-30x10WN ($\varnothing 10$ mm)
- E1-30x12WN ($\varnothing 12$ mm)
- E1-30x16 ($\varnothing 16$ mm)
- E1-30x20 ($\varnothing 20$ mm)
- E1-30x25 ($\varnothing 25$ mm)
- E1-30x32 ($\varnothing 32$ mm)
- E1-30x40 ($\varnothing 40$ mm)

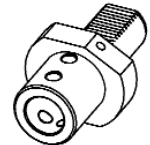

Toolholder for boring bar

- E2-30x6 ($\varnothing 6$ mm)
- E2-30x8 ($\varnothing 8$ mm)
- E2-30x10 ($\varnothing 10$ mm)
- E2-30x12 ($\varnothing 12$ mm)
- E2-30x16 ($\varnothing 16$ mm)
- E2-30x20 ($\varnothing 20$ mm)
- E2-30x25 ($\varnothing 25$ mm)
- E2-30x32 ($\varnothing 32$ mm)
- E2-30x40 ($\varnothing 40$ mm)

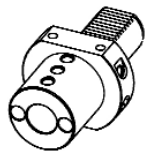

Double holder for boring bar

- E7-30x25 ($\varnothing 25$ mm)

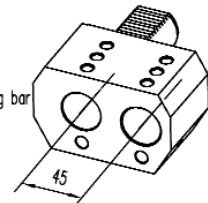

Toolholder with cylindrical shank

- 137-00041 ($\varnothing 40$ mm/HSK50A+C)



Collet chuck

- E4-30x16 (ER16)
- E4-30x20 (ER20)
- E4-30x25 (ER25)
- E4-30x32 (ER32)
- E4-30x40 (ER40)

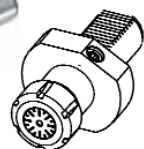

Drilling chuck

- KS2-30-13 ($\varnothing 1$ - $\varnothing 13$ mm)
- KS2-30-16 ($\varnothing 3$ - $\varnothing 16$ mm)

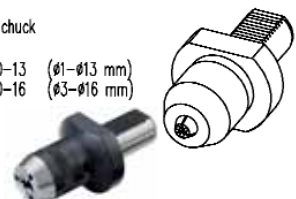

DMG MORI (VDI30)

CTX 310/410 V4/V6 - CTX 320 V4/V6
 CTX 420 V4/V6 (option) - CTX Alpha 300 V4
 CTX Alpha 500 V 4/V6
 CTX Beta 500/800/1250 V4/V6 (option)
 TWIN 42/65/102
 SPRINT 65/50

RADIAL TURRET

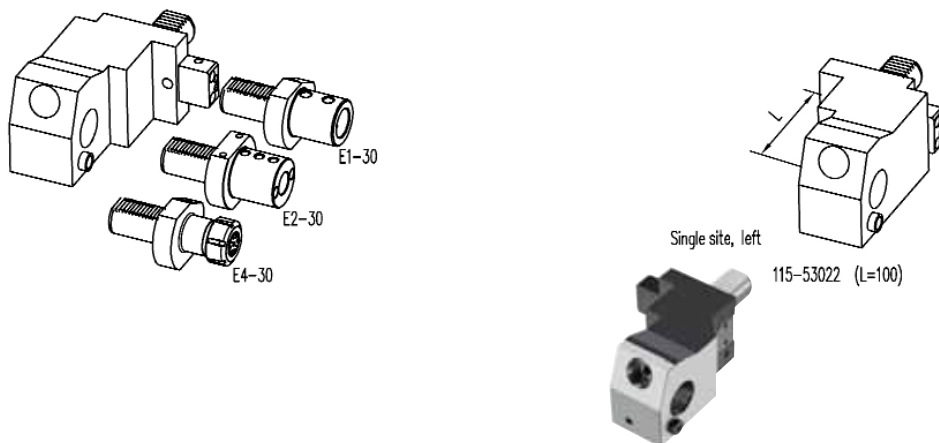
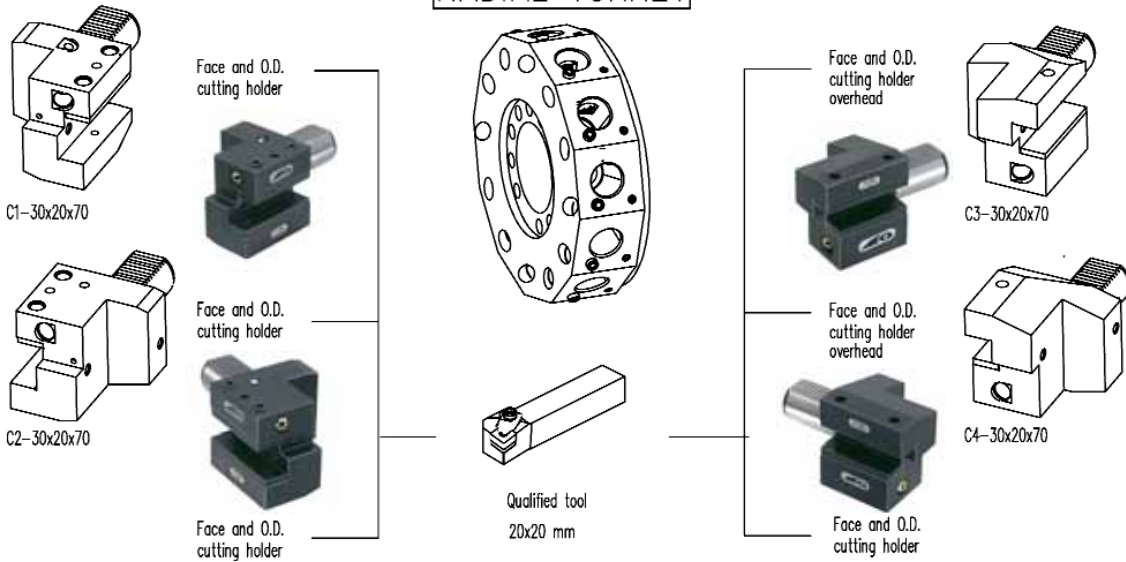

DMG MORI (VDI30)

CTX310/410 V4/V6 - CTX 320 V4/V6
 CTX420 V4/V6 (option) - CTX Alpha 300 V4
 CTX Alpha 500 V4/V6
 CTX Beta 500/800/1250 V4/V6 (option)
 TWIN 42/65/102
 SPRINT 65/50

RADIAL TURRET

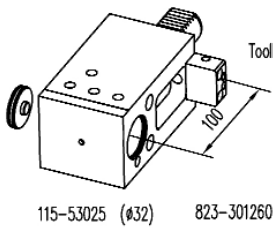

Toolholder for boring bar



115-53025 (Ø32) 823-301260

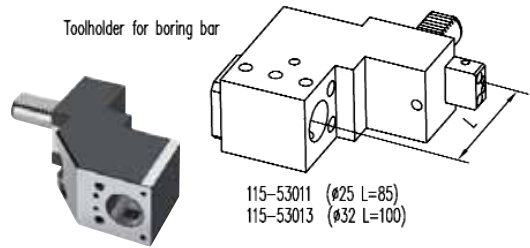

Toolholder for boring bar

115-53011 (Ø25 L=85)
 115-53013 (Ø32 L=100)

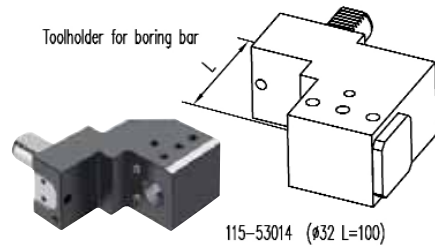

Toolholder for boring bar

115-53014 (Ø32 L=100)

ACCESSORIES

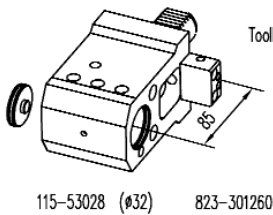

Toolholder for boring bar



115-53028 (Ø32) 823-301260

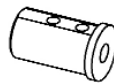

Boring bar sleeve Ø32 mm

165-63301 (Ø6 mm)
 165-63302 (Ø8 mm)
 165-63303 (Ø10 mm)
 165-63304 (Ø12 mm)

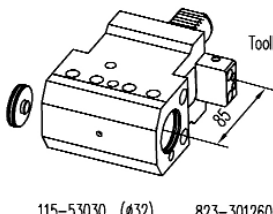

Toolholder for boring bar



115-53030 (Ø32) 823-301260

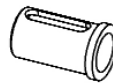

Boring bar sleeve Ø25 mm

165-62523 (Ø16 mm)
 165-62524 (Ø20 mm)

Boring bar sleeve Ø32 mm

165-63305 (Ø16 mm)
 165-63306 (Ø20 mm)
 165-63307 (Ø25 mm)

DMG MORI (VDI40)

CTX410 V3 (option)
 CTX510 V3/V4
 CTX420 V3 (option)
 CTX520 V3/V4
 CTX Beta 500/800/1250 V3/V4
 CTX Gamma 1250/2000 V3/V4 (option)

AXIAL TURRET

Face and O.D. cutting holder

B1-40X25X44

Face and O.D. cutting holder overhead

B3-40X25X44

Face and O.D. cutting holder

B5-40X25X44

Face and O.D. cutting holder overhead

B7-40X25X44

Cut-off holder
26 mm/32 mm

AR4026
AR4032

Bar puller

KH1-40

VDI damped, adjustable, stop bar

MW-4042-AM

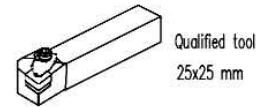
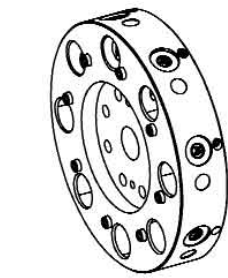

ACCESSORIES



Boring bar sleeve $\varnothing 25$ mm

- 115-62579 ($\varnothing 8$ mm)
- 115-62580 ($\varnothing 10$ mm)
- 115-62581 ($\varnothing 12$ mm)
- 115-62582 ($\varnothing 16$ mm)
- 115-62583 ($\varnothing 20$ mm)

Boring bar sleeve $\varnothing 32$ mm

- 165-63223 ($\varnothing 8$ mm)
- 165-63224 ($\varnothing 10$ mm)
- 165-63225 ($\varnothing 12$ mm)
- 165-63226 ($\varnothing 16$ mm)
- 165-63227 ($\varnothing 20$ mm)
- 165-63228 ($\varnothing 25$ mm)

Boring bar sleeve $\varnothing 40$ mm

- 165-64082 ($\varnothing 8$ mm)
- 165-64083 ($\varnothing 10$ mm)
- 165-64084 ($\varnothing 12$ mm)
- 165-64085 ($\varnothing 16$ mm)
- 165-64086 ($\varnothing 20$ mm)
- 165-64087 ($\varnothing 25$ mm)
- 165-64088 ($\varnothing 32$ mm)

Toolholder for insert drill

- E1-40x06WN ($\varnothing 6$ mm)
- E1-40x08WN ($\varnothing 8$ mm)
- E1-40x10WN ($\varnothing 10$ mm)
- E1-40x12WN ($\varnothing 12$ mm)
- E1-40x16 ($\varnothing 16$ mm)
- E1-40x20 ($\varnothing 20$ mm)
- E1-40x25 ($\varnothing 25$ mm)
- E1-40x32 ($\varnothing 32$ mm)
- E1-40x40 ($\varnothing 40$ mm)
- E1-40x50 ($\varnothing 50$ mm)

Toolholder for boring bar

- E2-40x6 ($\varnothing 6$ mm)
- E2-40x8 ($\varnothing 8$ mm)
- E2-40x10 ($\varnothing 10$ mm)
- E2-40x12 ($\varnothing 12$ mm)
- E2-40x16 ($\varnothing 16$ mm)
- E2-40x20 ($\varnothing 20$ mm)
- E2-40x25 ($\varnothing 25$ mm)
- E2-40x32 ($\varnothing 32$ mm)
- E2-40x40 ($\varnothing 40$ mm)
- E2-40x50 ($\varnothing 50$ mm)

Double holder for boring bar

E7-40x32 ($\varnothing 32$ mm)

Toolholder for boring bar

118-04013 (HSK63A+C)

Collet chuck

- E4-40x20 (ER20)
- E4-40x25 (ER25)
- E4-40x32 (ER32)
- E4-40x40 (ER40)

Drilling chuck

- KS2-40-13 ($\varnothing 1$ - $\varnothing 13$ mm)
- KS2-40-16 ($\varnothing 3$ - $\varnothing 16$ mm)

DMG MORI (VDI40)

CTX410 V4/V6 (option) - CTX420 V4/V6
 CTXBeta 500/800/1250 V6
 TWIN42/65/102 RG2 - GMX250/300/400/500
 SPRINT65 (option)

RADIAL TURRET

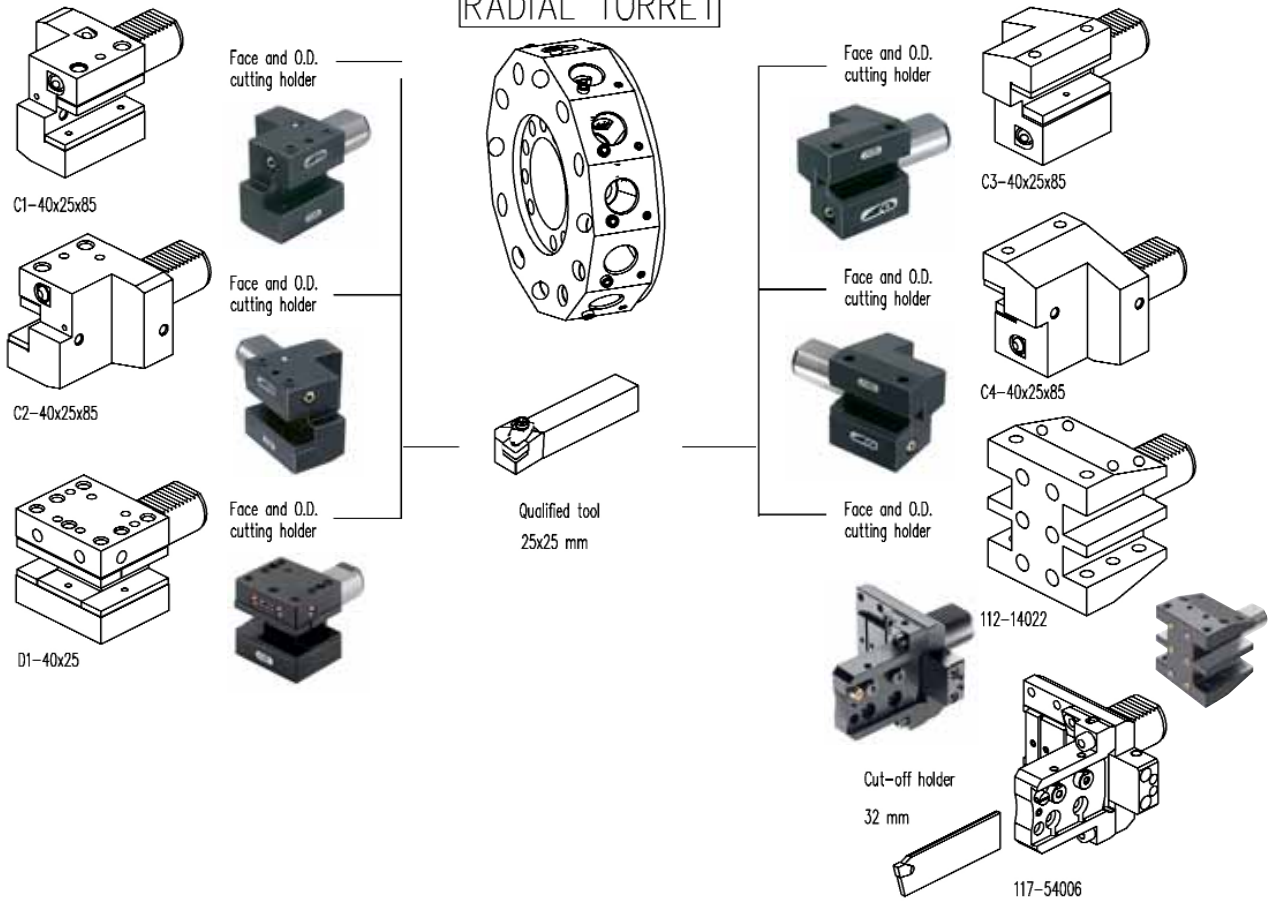

VDI40/VDI40 ADAPTORS

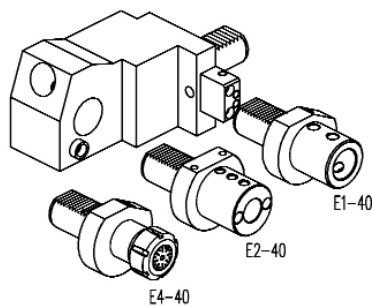

DMG MORI
(VDI40)

CTX410 V4/V6 (option) - CTX420 V4/V6
 CTXBeta 500/800/1250 V4/V6
 TWIN42/65/102 RG2 - GMX250/300/400/500
 SPRINT65 (option)

RADIAL TURRET

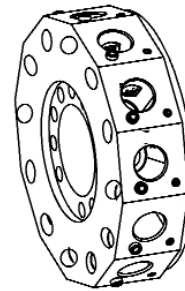
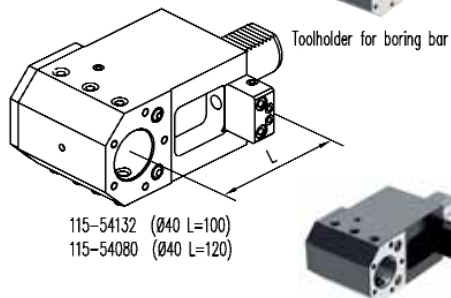
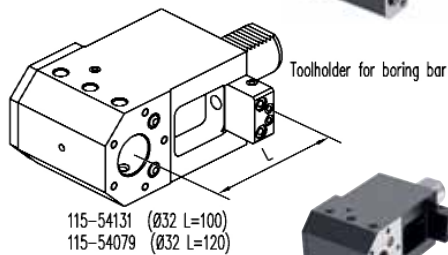
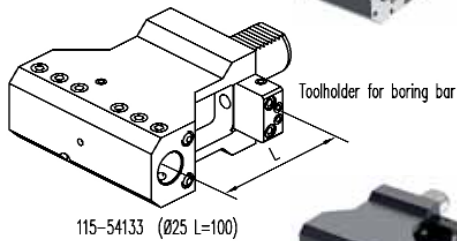
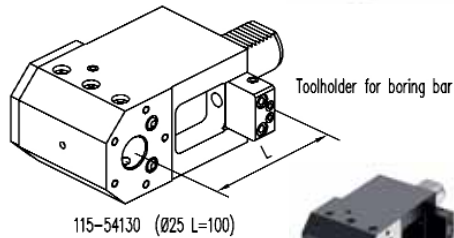
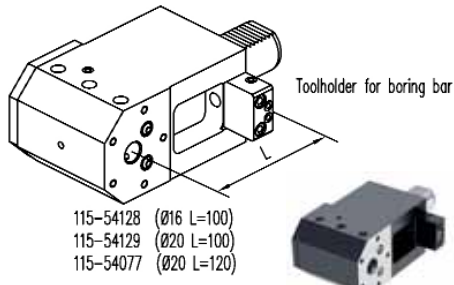

ACCESSORIES



- Boring bar sleeve (Ø25)
- 115-62579 (Ø8)
 - 115-62580 (Ø10)
 - 115-62581 (Ø12)
 - 115-62582 (Ø16)
 - 115-62583 (Ø20)

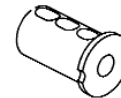

- | | |
|-------------------------|-------------------------|
| Boring bar sleeve (Ø32) | Boring bar sleeve (Ø40) |
| 165-63223 (Ø8) | 165-64082 (Ø8) |
| 165-63224 (Ø10) | 165-64083 (Ø10) |
| 165-63225 (Ø12) | 165-64084 (Ø12) |
| 165-63226 (Ø16) | 165-64085 (Ø16) |
| 165-63227 (Ø20) | 165-64086 (Ø20) |
| 165-63228 (Ø25) | 165-64087 (Ø25) |
| | 165-64088 (Ø32) |

Double toolholder for boring bar

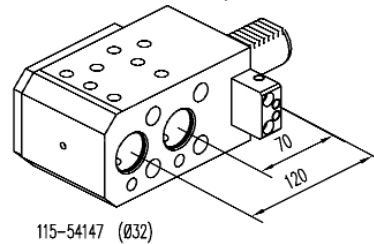

AXIAL TURRET

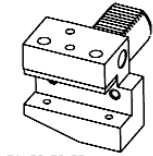

B1-50x32x55

Face and O.D. cutting holder



B3-50x32x55

Face and O.D. cutting holder overhead

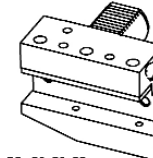

B5-50x32x55

Face and O.D. cutting holder

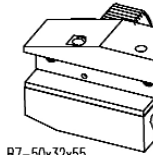

B7-50x32x55

Face and O.D. cutting holder overhead

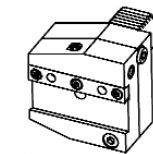

AR5026
AR5032

Cut-off holder
26 mm/32 mm

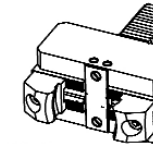

KH1-50

Bar puller

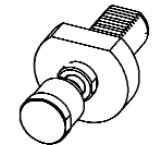

MW-5042-AM

VDI damped, adjustable, stop bar

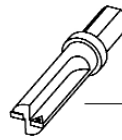
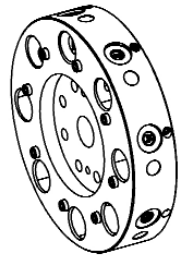

Toolholder for insert drill

- E1-50x16 (ø16 mm)
- E1-50x20 (ø20 mm)
- E1-50x25 (ø25 mm)
- E1-50x32 (ø32 mm)
- E1-50x40 (ø40 mm)
- E1-50x50 (ø50 mm)

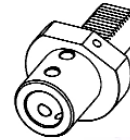

Toolholder for boring bar

- E2-50x12 (ø12 mm)
- E2-50x16 (ø16 mm)
- E2-50x20 (ø20 mm)
- E2-50x25 (ø25 mm)
- E2-50x32 (ø32 mm)
- E2-50x40 (ø40 mm)
- E2-50x50 (ø50 mm)

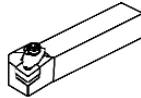

Qualified tool
32x32 mm

ACCESSORIES



E2-115

Boring bar sleeve ø25 mm

- 115-62584 (ø8 mm)
- 115-62585 (ø10 mm)
- 115-62586 (ø12 mm)
- 115-62587 (ø16 mm)
- 115-62588 (ø20 mm)

Boring bar sleeve ø32 mm

- 165-63229 (ø8 mm)
- 165-63230 (ø10 mm)
- 165-63231 (ø12 mm)
- 165-63232 (ø16 mm)
- 165-63233 (ø20 mm)
- 165-63234 (ø25 mm)

Boring bar sleeve ø40 mm

- 165-64082 (ø8 mm)
- 165-64083 (ø10 mm)
- 165-64084 (ø12 mm)
- 165-64085 (ø16 mm)
- 165-64086 (ø20 mm)
- 165-64087 (ø25 mm)
- 165-64088 (ø32 mm)

Toolholder for boring bar

- E2-50x12 (ø12 mm)
- E2-50x16 (ø16 mm)
- E2-50x20 (ø20 mm)
- E2-50x25 (ø25 mm)
- E2-50x32 (ø32 mm)
- E2-50x40 (ø40 mm)
- E2-50x50 (ø50 mm)

Double holder for boring bar

- E7-50x32 (ø32 mm L=50 mm)
- E7-50x50 (ø50 mm L=68 mm)

Collet chuck

- E4-50x25 (ER25)
- E4-50x32 (ER32)
- E4-50x40 (ER40)

Drilling chuck

- KS2-50-13 (ø1-ø13 mm)
- KS2-50-16 (ø3-ø16 mm)

ATC Turret (HSK63T)

ICTM STANDARD

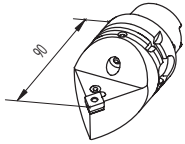

H63APCMNR12-90

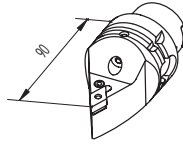

H63APDNNR15-90

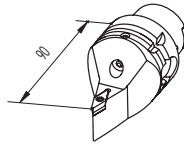

H63ASVVCN16-90

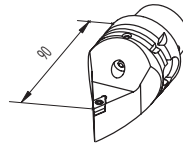

H63ASDNCN11-90

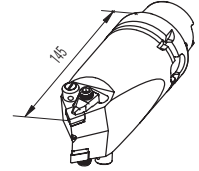

H63ADCM12DDM15-L145

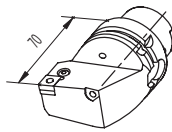

H63APCLNL/R12

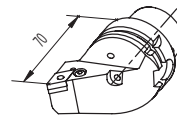

H63APDJNL/R15

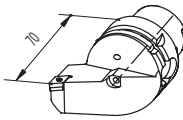

H63ASDJCL/R11

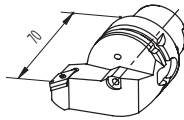

H63ASVJBL/R16

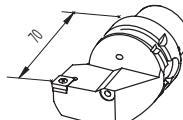

H63ASCLCL/R12

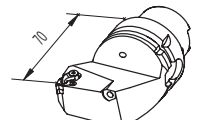

H63ATHEL/R16

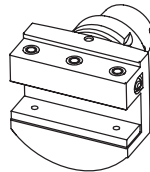

141-11408 32/25

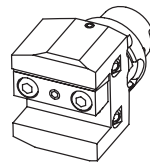

141-11406 25x25 mm

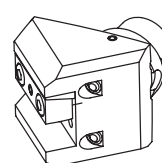

141-11405 25x25 mm

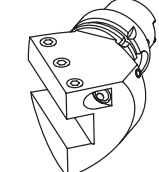

141-11407 (left) 25x25 mm
141-21401 (right)

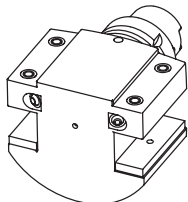

142-11405 32/25
142-11406 32/25

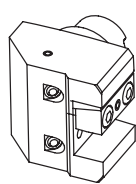

142-11402 25x25 mm

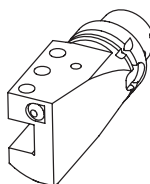

142-21401 (left) 25x25 mm
142-11403 (right)

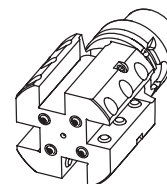

142-21404 20x20 mm (right)
142-21403 20x20 mm (left)

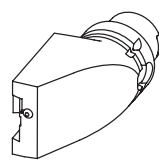

147-51405 (26mm, left)
147-51406 (26mm, right)
147-51407 (32mm, left)
147-51408 (32mm, right)

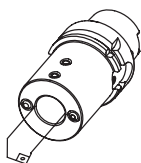

145-21404 (Ø12)
145-21406 (Ø16)
145-21408 (Ø20)
145-21409 (Ø25)
145-21410 (Ø32)
145-21411 (Ø40)

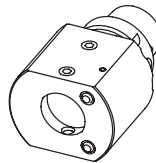

145-21412 Ø40 mm

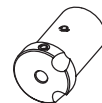

165-64124 (Ø10 mm)
165-64125 (Ø12 mm)
165-64126 (Ø16 mm)
165-64127 (Ø20 mm)

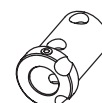

165-64128 (Ø25 mm)
165-64129 (Ø32 mm)

DMG MORI CTX310ECO-BMT / NZ1500 / NZ2000

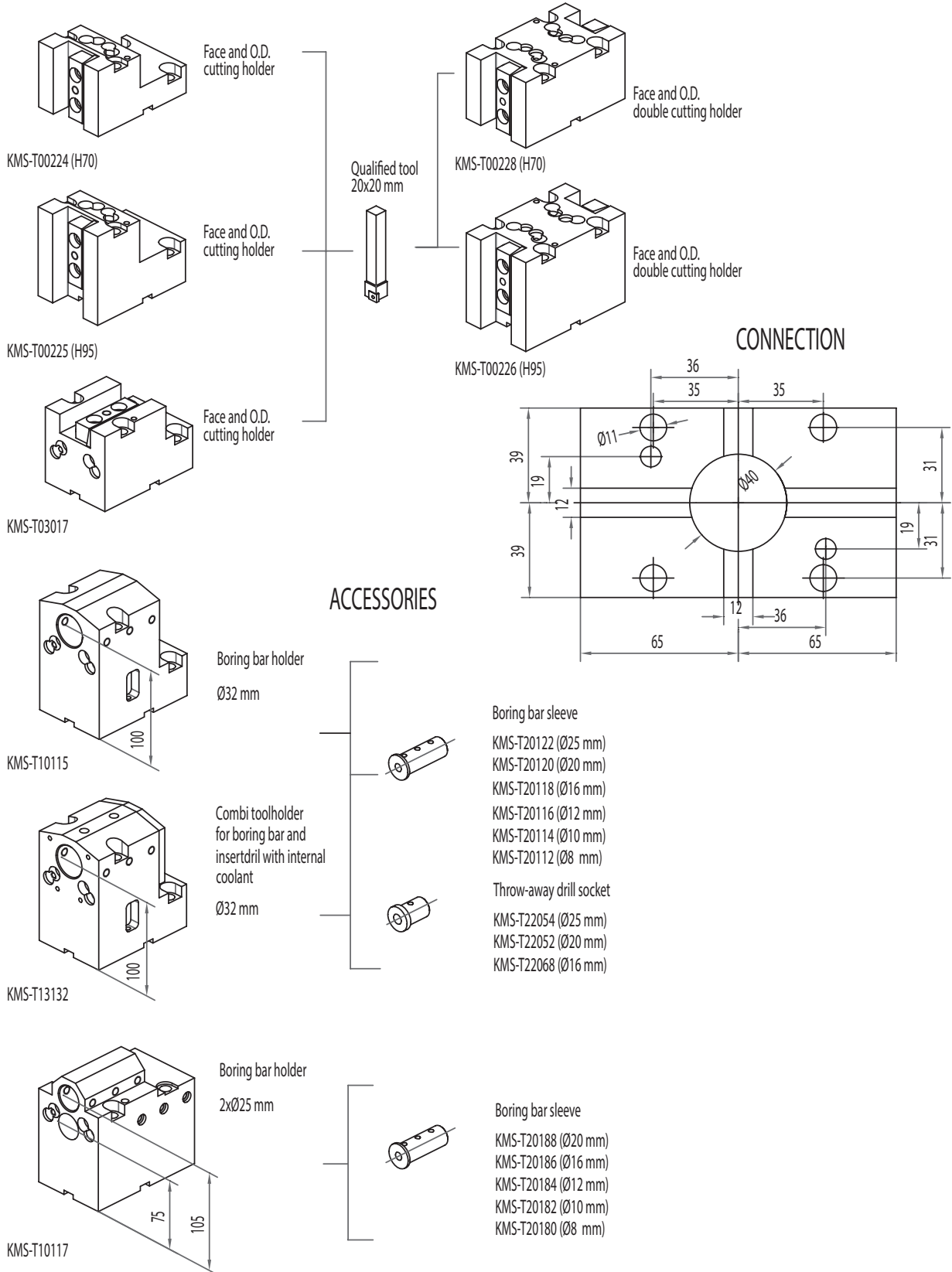

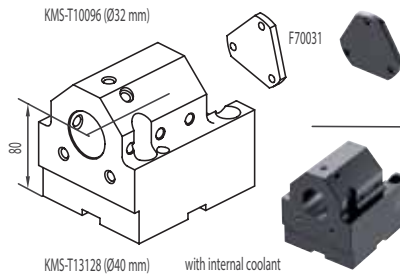
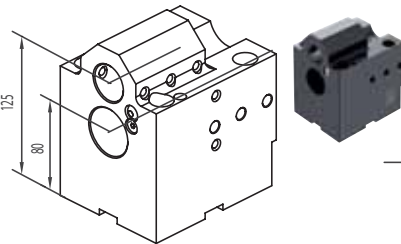
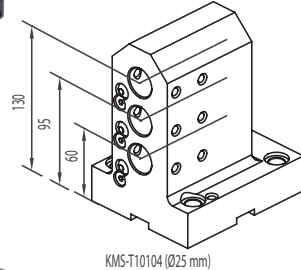
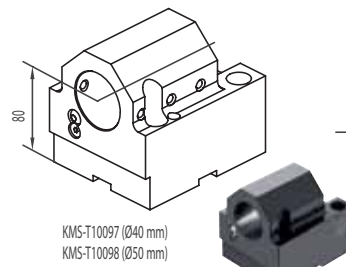
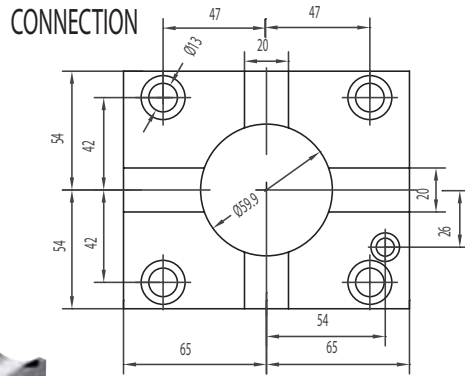
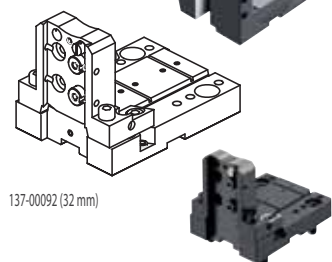
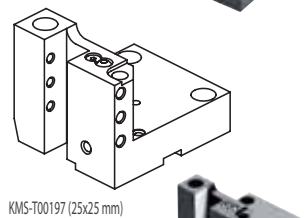
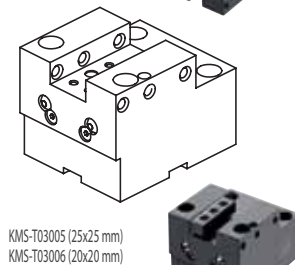
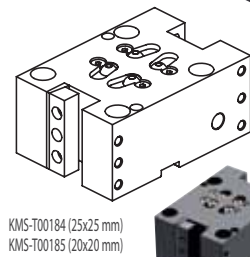
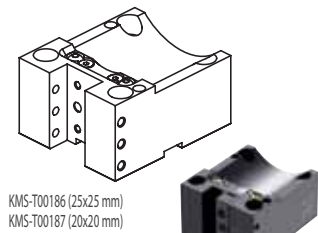
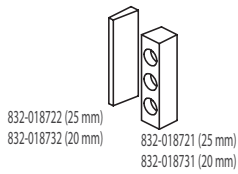

Driven tools

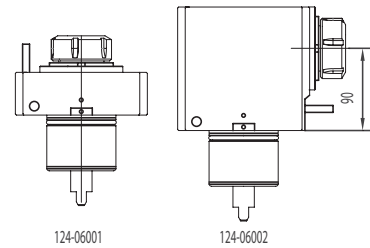

ACCESSORIES

- KMS-T20098-A (Ø32 mm)
- KMS-T20096-A (Ø25 mm)
- KMS-T20094-A (Ø20 mm)
- KMS-T20092-A (Ø16 mm)
- KMS-T20090-A (Ø12 mm)
- KMS-T20088-A (Ø10 mm)
- KMS-T20086-A (Ø8 mm)

- KMS-T20196-A (Ø20 mm)
- KMS-T20194-A (Ø16 mm)
- KMS-T20110-A (Ø12 mm)
- KMS-T20108-A (Ø10 mm)
- KMS-T20106-A (Ø8 mm)

- KMS-T2042-A (MT3)
- KMS-T2044-A (MT4)
- KMS-T2046-A (MT2)
- KMS-T2066-A (MT1)

- KMS-T20188 (Ø20 mm)
- KMS-T20186 (Ø16 mm)
- KMS-T20184 (Ø12 mm)
- KMS-T20182 (Ø10 mm)
- KMS-T20180 (Ø8 mm)

- KMS-T20122-A (Ø25 mm)
- KMS-T20120-A (Ø20 mm)
- KMS-T20118-A (Ø16 mm)
- KMS-T20116-A (Ø12 mm)
- KMS-T20114-A (Ø10 mm)
- KMS-T20112-A (Ø8 mm)

- KMS-T20100-A (Ø32 mm)
- KMS-T20102-A (Ø25 mm)
- KMS-T20104-A (Ø20 mm)
- KMS-T20190-A (Ø16 mm)

DMG MORI CMZ

SL203MC - SL253MC - ZL200MC
ZL250SMC - SL204SMC - SL300MC
TL20 - TL25 - TC30 - TC35

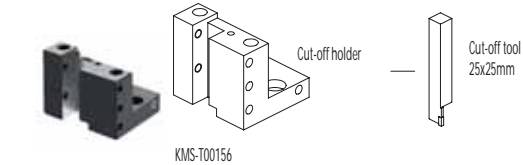
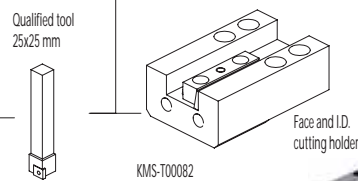
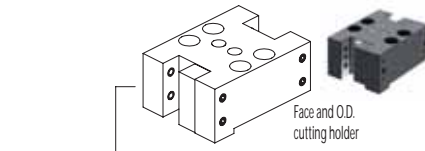
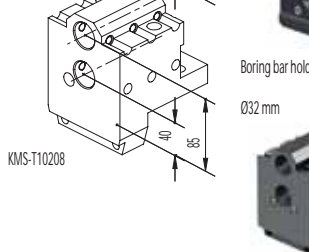
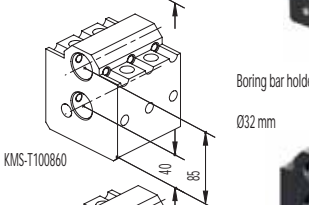
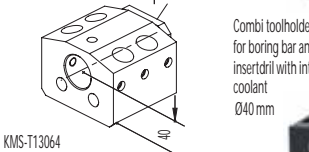
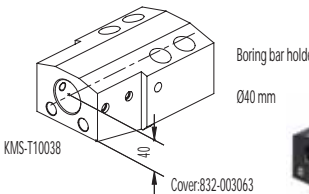
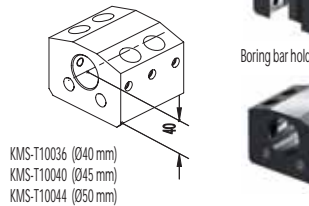
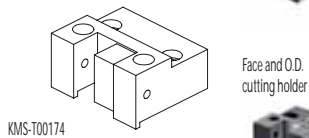
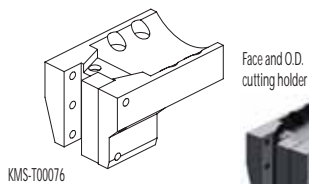
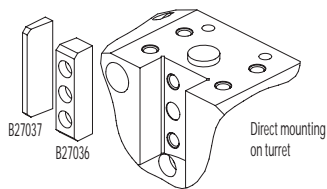

ACCESSORIES



CONNECTION

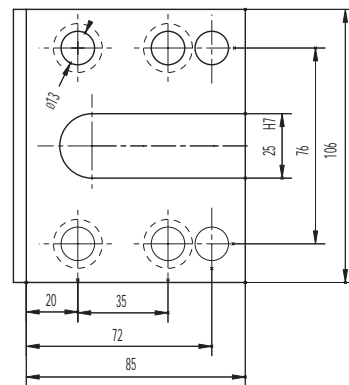

DMG MORI CTX Gamma 1250TC / 2000TC

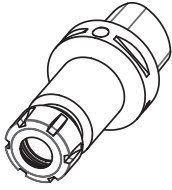

C63H60ER16 C63H100ER16
 C63H60ER20 C63H100ER20
 C63H60ER25 C63H100ER25
 C63H60ER32 C63H100ER32
 C63H70ER40 C63H130ER40



C63H55WE06 C63H65WE16
 C63H55WE08 C63H65WE20
 C63H60WE10 C63H80WE25
 C63H60WE12 C63H90WE32
 C63H60WE14

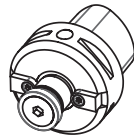

C63H40D16 C63H100D27
 C63H63D16 C63H25D32
 C63H25D22 C63H100D32
 C63H100D22 C63H40D40
 C63H25D27 C63H100D40

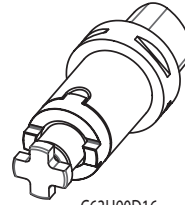

C63H90D16
 C63H90D22
 C63H90D27
 C63H90D32
 C63H90D40

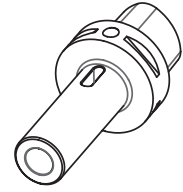

C63H110CM2P
 C63H130CM3P
 C63H150CM4P

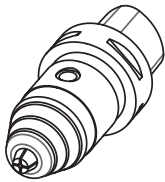

C63H112R1-13
 C63H112R3-16

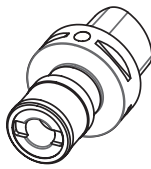

C63GR1
 C63GR2

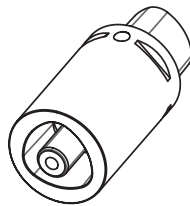

C63H100C63
 C63H140C63

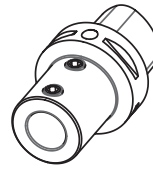

C63H60D08PNT
 C63H60D10PNT
 C63H60D12PNT
 C63H70D16PNT
 C63H70D20PNT
 C63H72D25PNT
 C63H75D32PNT
 C63H75D40PNT

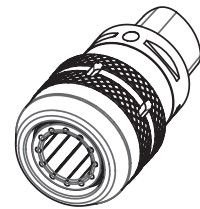

C63H80C20
 C63H100C32

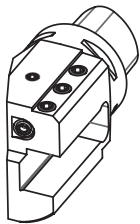

C63-AD2020R/L
 C63-AD2525R/L
 C63-AD3232R/L

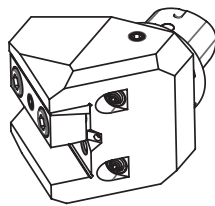

C63-ARD2525-45

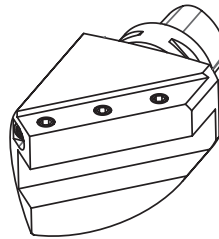

C63AR20R/L
 C63AR25R/L

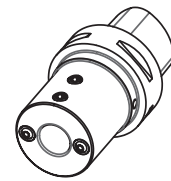

C63H80D16E2
 C63H80D20E2
 C63H88D25E2
 C63H95D32E2
 C63H105D40E2

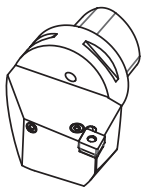

C63-PCLNR/L12
 C63-PCLNR/R16



C63-PDJNR/L15

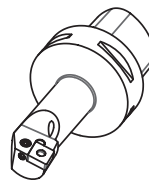

C63-25PCLNR/L12
 C63-32PCLNR/L12
 C63-40PCLNR/L16
 C63-50PCLNR/L16

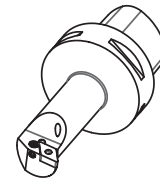

C63-25PDUNR/L11
 C63-32PDUNR/L15
 C63-40PDUNR/L15
 C63-50PDUNR/L15

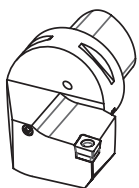

C63-SCLCR/L09
 C63-SCLCR/R12

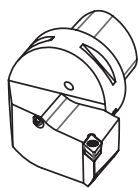

C63-SDJCR/L11



C63-SVHBR/L16
 C63-SVHCR/L16



C63-SVJBR/L16
 C63-SVJCR/L16

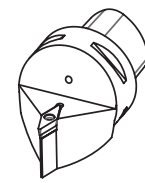

C63-SVBN16-190
 C63-SVVCN16-190

DMG MORI SL150 - SL153 - ZL150 - CL150 - SL154

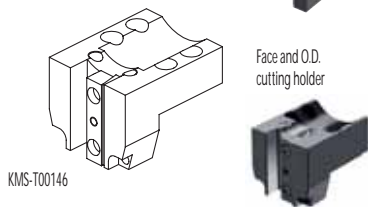
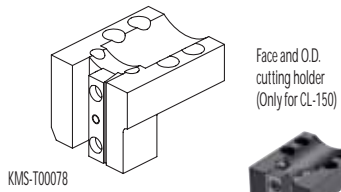
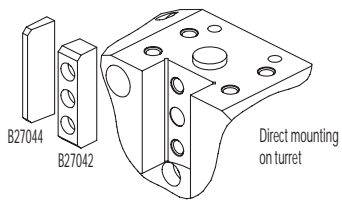

Qualified tool
20x20 mm

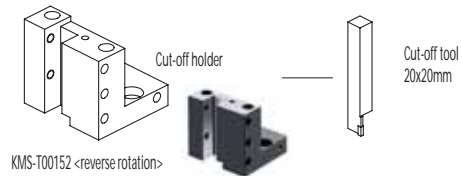
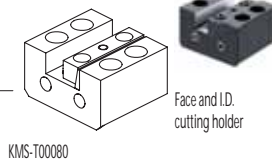
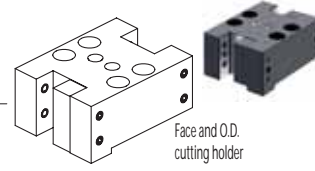

ACCESSORIES

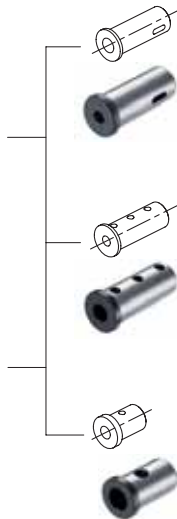
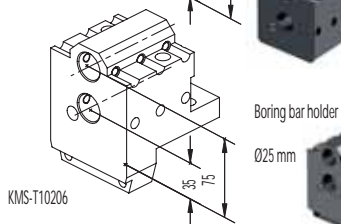
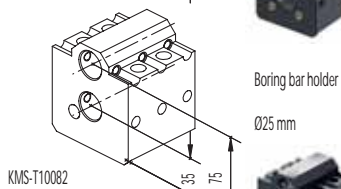
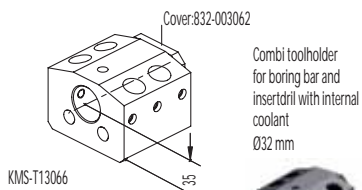
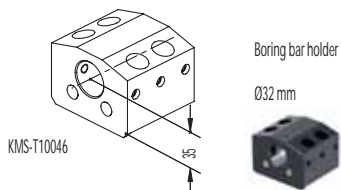

Drill socket

KMS-T22048 <MT2>

Boring bar sleeve

KMS-T20122 (Ø25 mm)
KMS-T20120 (Ø20 mm)
KMS-T20118 (Ø16 mm)
KMS-T20116 (Ø12 mm)
KMS-T20114 (Ø10 mm)
KMS-T20112 (Ø8 mm)

Throw-away drill socket

KMS-T22054 (Ø25 mm)
KMS-T22052 (Ø20 mm)
KMS-T22068 (Ø16 mm)

Boring bar sleeve

KMS-T20188 (Ø20 mm)
KMS-T20186 (Ø16 mm)
KMS-T20184 (Ø12 mm)
KMS-T20182 (Ø10 mm)
KMS-T20180 (Ø8 mm)

CONNECTION

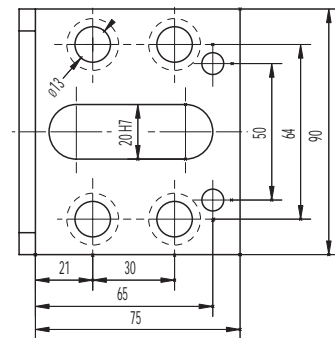

DMG MORI CMZ

SL153MC - ZL150MC - SL154MC
TL15

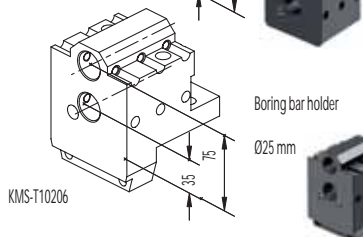
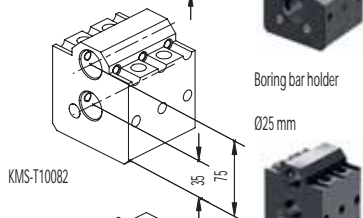
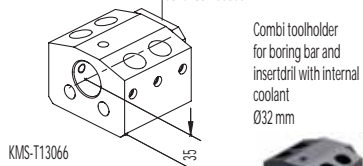
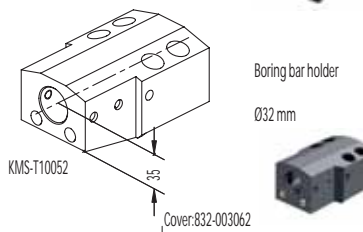
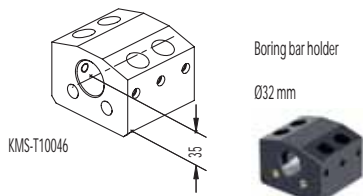
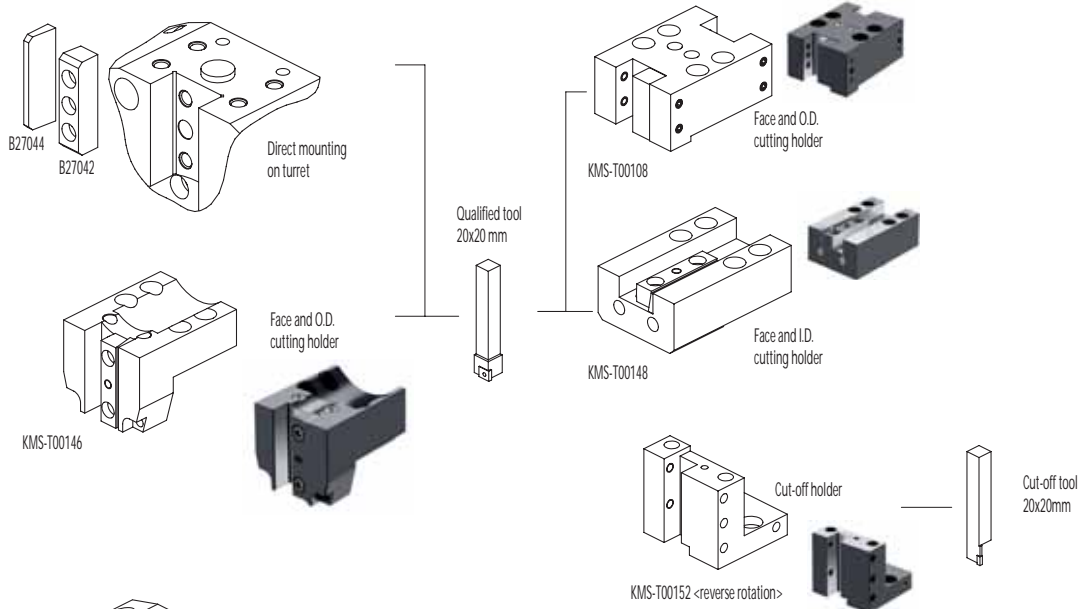

ACCESSORIES

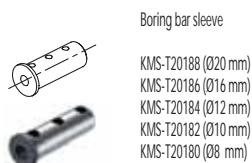

CONNECTION

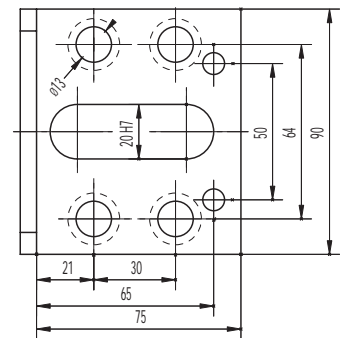

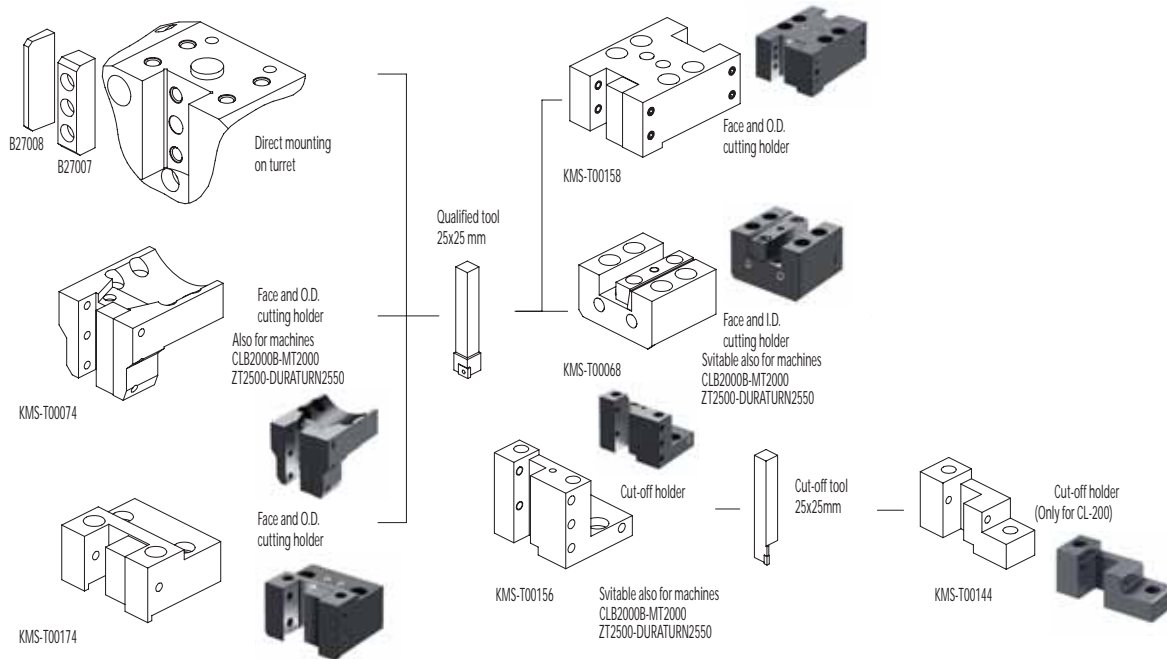

ACCESSORIES

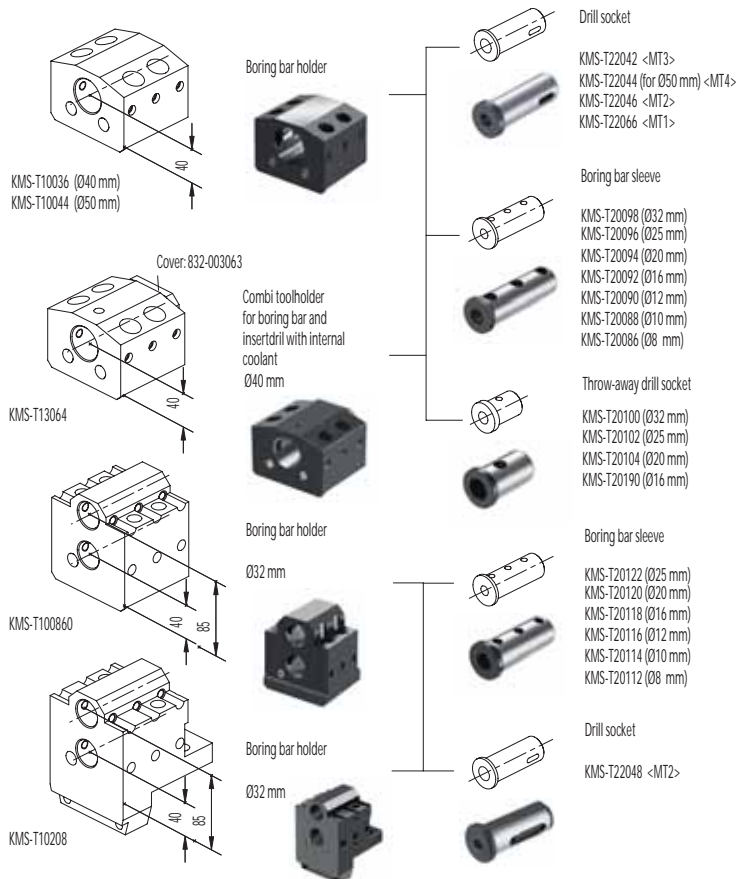

CONNECTION

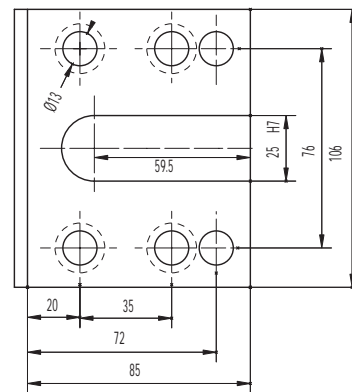

DMG MORI CXT620

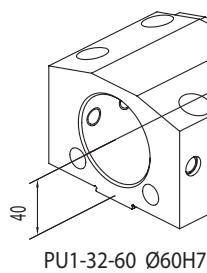
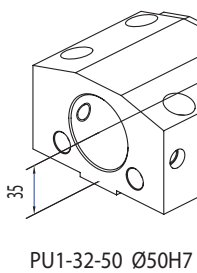
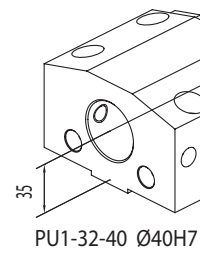
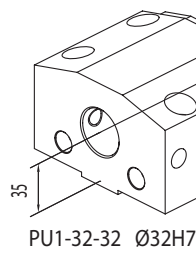
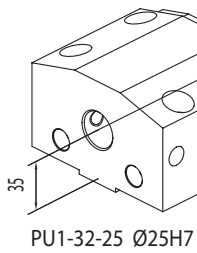
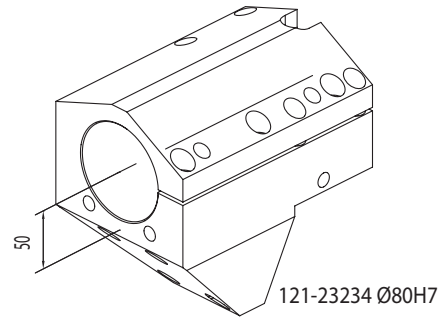
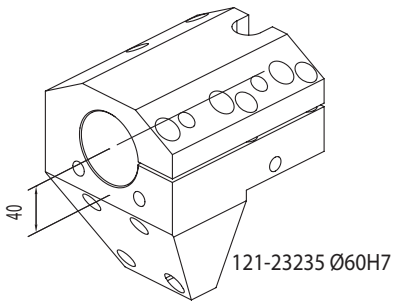
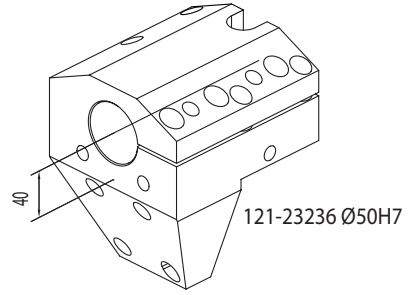
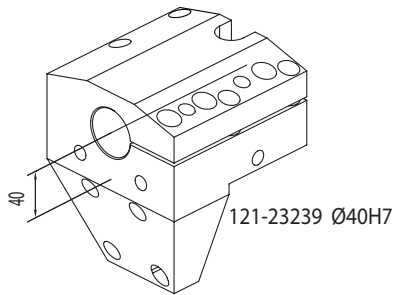

DMG MORI CTX510

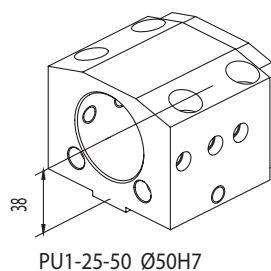
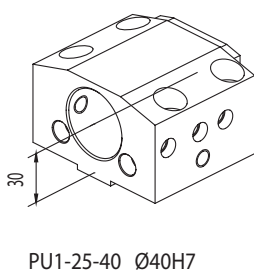
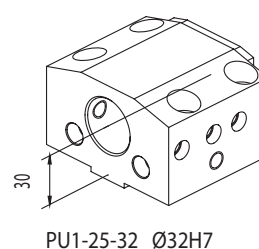
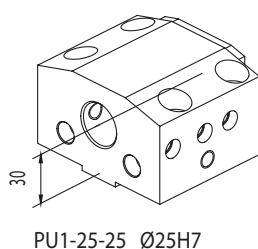
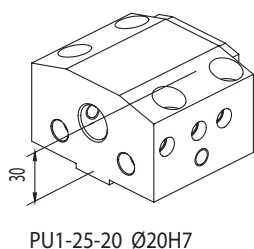
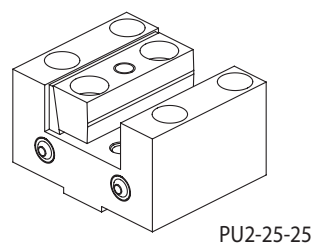
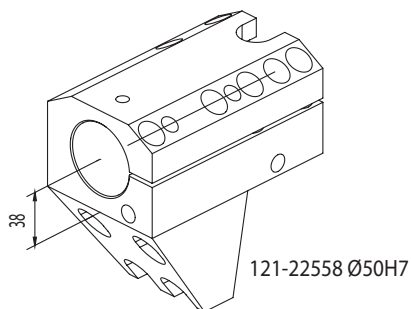
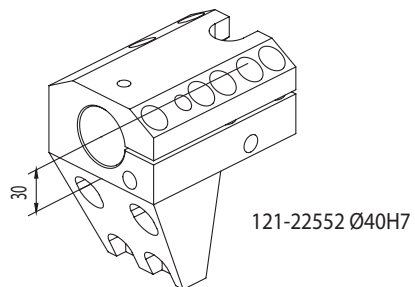

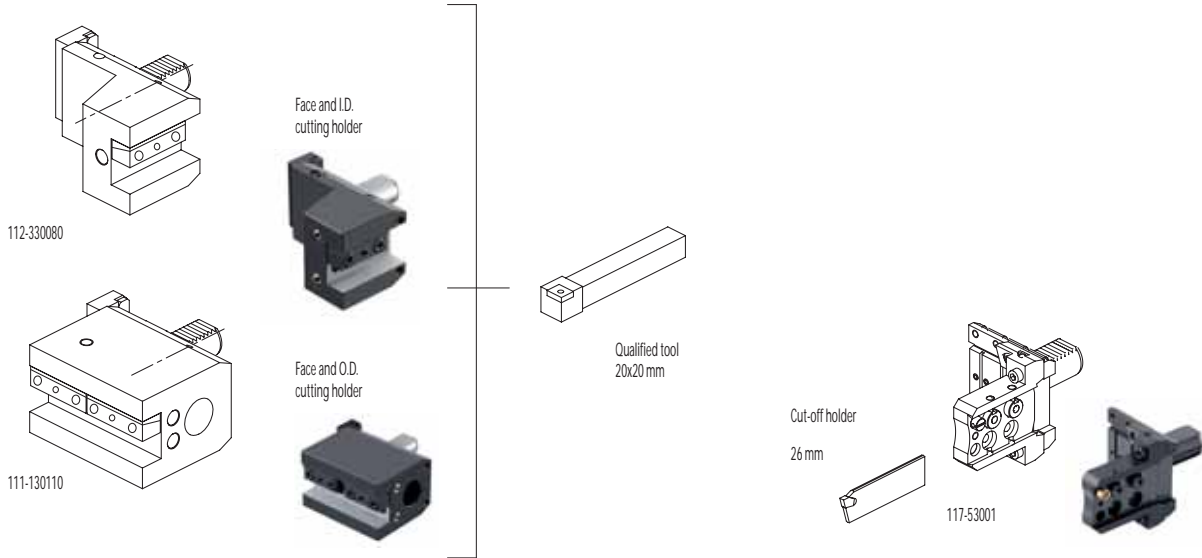

ACCESSORIES

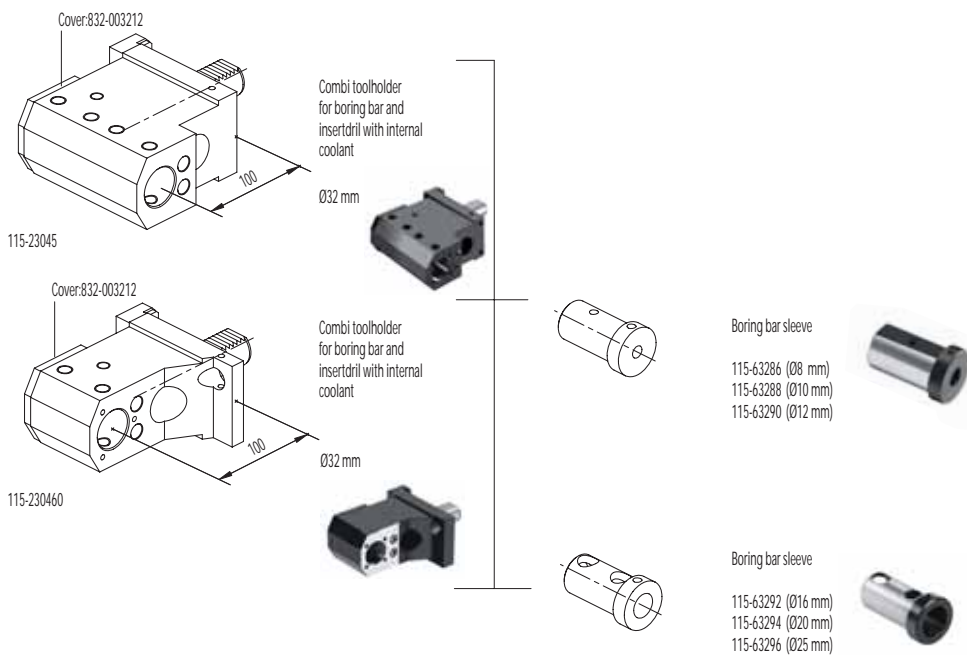

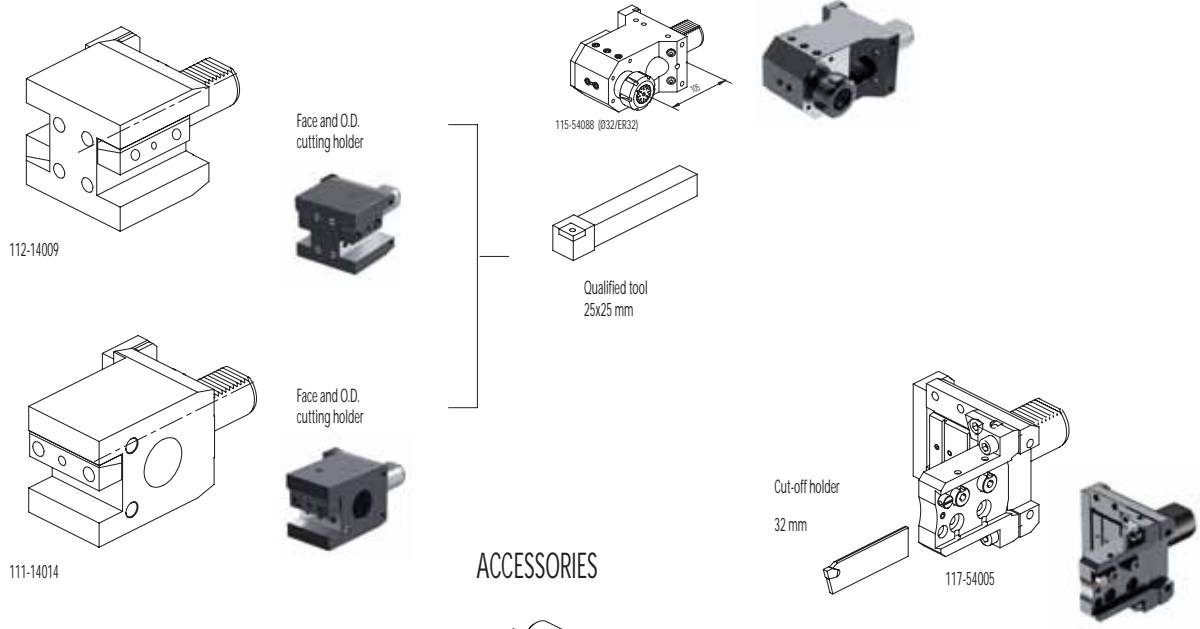

ACCESSORIES

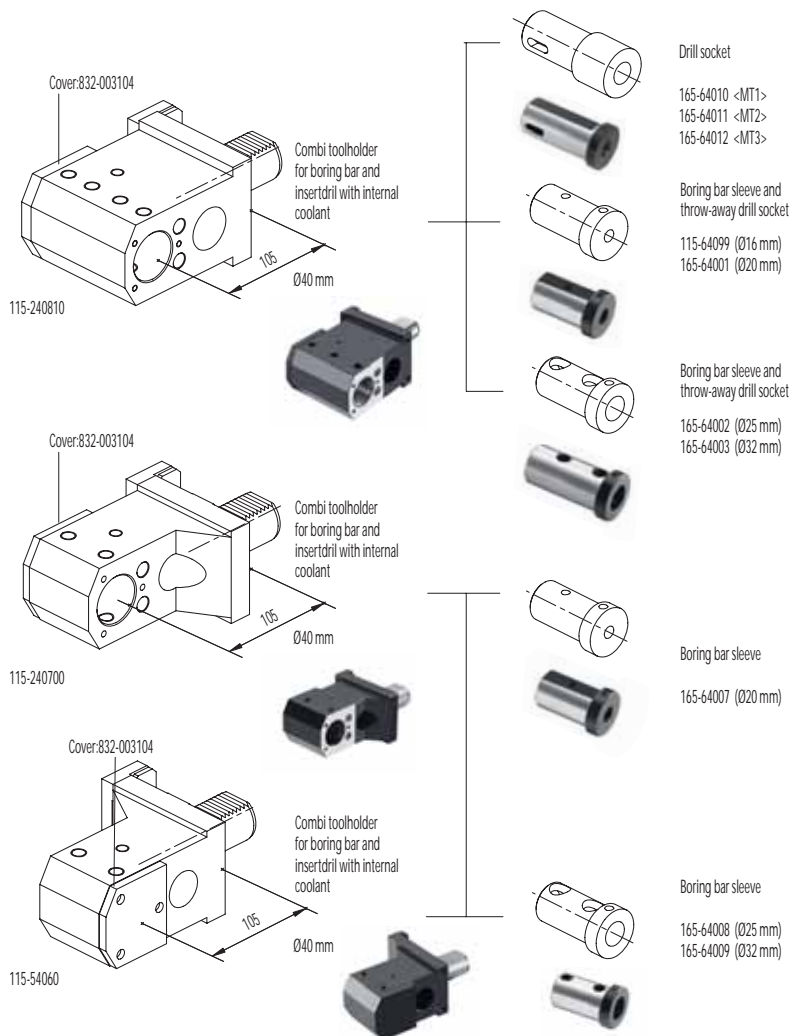

OKUMA LB15 - LB25
LB15II - LB300

HAAS SL20 - SL30

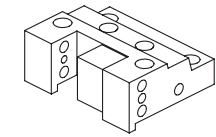

128-420110

Face and O.D.
cutting holder

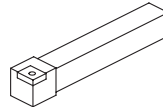

Qualified tool
25x25 mm

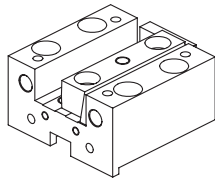

128-32001

Face and I.D.
cutting holder



CONNECTION

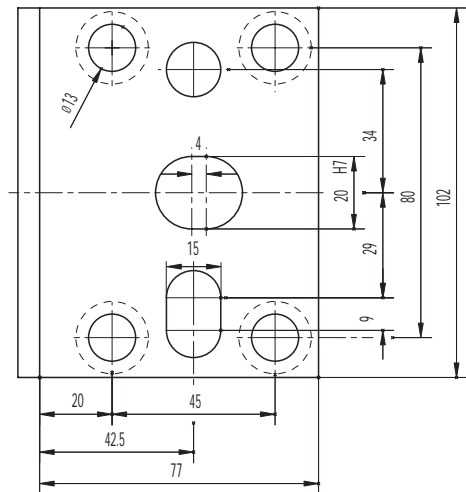

ACCESSORIES

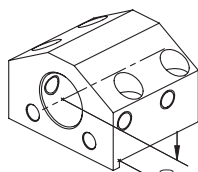

128-22001

Toolholder
for boring bar

Ø40 mm

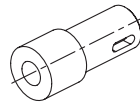

Drill socket

165-64010 <MT1>
165-64011 <MT2>
165-64012 <MT3>



Boring bar sleeve and
throw-away drill socket

165-64135 (Ø8 mm)
165-64013 (Ø10 mm)
165-64014 (Ø12 mm)
165-64015 (Ø16 mm)
165-64016 (Ø20 mm)

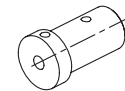

Boring bar sleeve and
throw-away drill socket

165-64017 (Ø25 mm)
165-64018 (Ø32 mm)

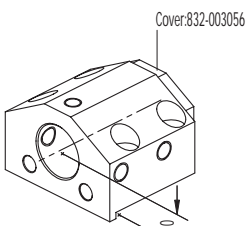

128-22005

Cover:832-003056

Combi toolholder
for boring bar and
insert drill with internal
coolant

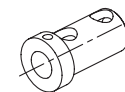

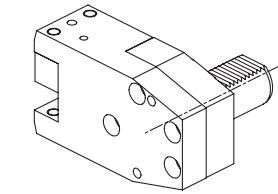

112-240070

Face and I.D.
cutting holder

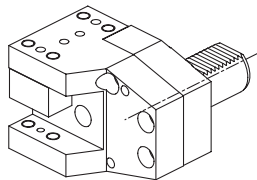

111-640050

Face and O.D.
cutting holder

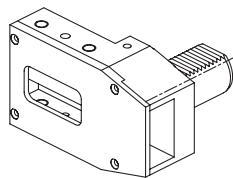

111-640060

Face and O.D.
cutting holder

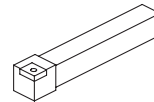

Qualified tool
25x25 mm

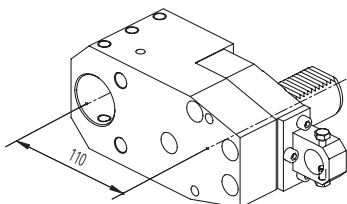

115-240680

Toolholder
for boring bar



ACCESSORIES

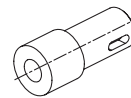

Drill socket

- 165-64010 <MT1>
- 165-64011 <MT2>
- 165-64012 <MT3>

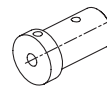

Boring bar sleeve

- 165-64024 (Ø10 mm)
- 165-64025 (Ø12 mm)
- 165-64026 (Ø16 mm)
- 165-64027 (Ø20 mm)



OKUMA (HSK63T)

Mac Turn 250/350/400 Multus B250/B300/B400

For turning

ATC Turret (HSK63T)

ICTM STANDARD

45°

90°

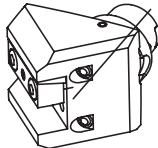

141-11405 25x25 mm

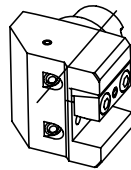

142-11402 25x25 mm

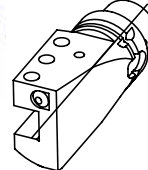

142-21401 (left) 25x25 mm
142-11403 (right)

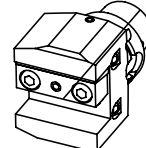

141-11406 25x25 mm

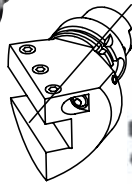

141-11407 (left) 25x25 mm
141-21401 (right)

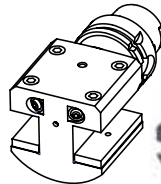

142-11405 32x32/25x25 mm

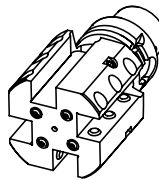

142-21403 20x20 mm (left)
142-21404 20x20 mm (right)

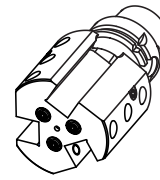

142-21402 20x20 mm (left)
142-11404 20x20 mm (right)

CUT-OFF HOLDER

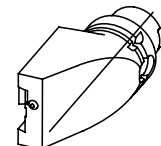

147-51405 (26mm, left)
147-51406 (26mm, right)
147-51407 (32mm, left)
147-51408 (32mm, right)

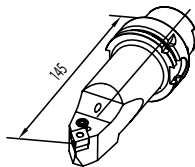

H63APCMNR12-L145

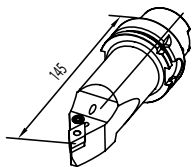

H63APDNNR15-L145

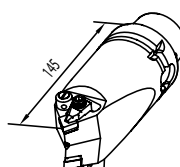

H63ADCM12DDM15-L145

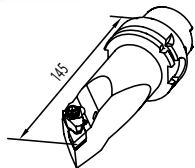

H63ADDMNL15-L145

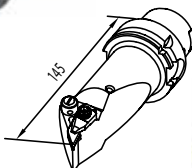

H63ADVMNL16-L145

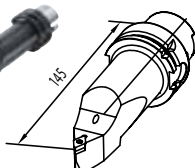

H63ASDNCN11-L145

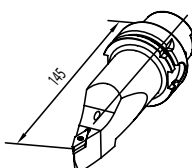

H63ASVWCN16-L145

BORING BAR HOLDER

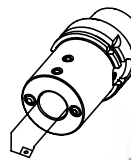

145-21404 (Ø12)
145-21406 (Ø16)
145-21408 (Ø20)
145-21409 (Ø25)
145-21410 (Ø32)
145-21411 (Ø40)

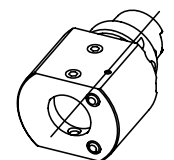

145-21412 Ø40 mm

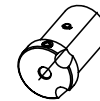

165-64124 (Ø10 mm)
165-64125 (Ø12 mm)
165-64126 (Ø16 mm)
165-64127 (Ø20 mm)



165-64128 (Ø25 mm)
165-64129 (Ø32 mm)

145-11406 (Ø16)
145-11408 (Ø20)
145-11409 (Ø25)
145-11410 (Ø32)
145-11411 (Ø40)

Lower Turret (VDI 40)

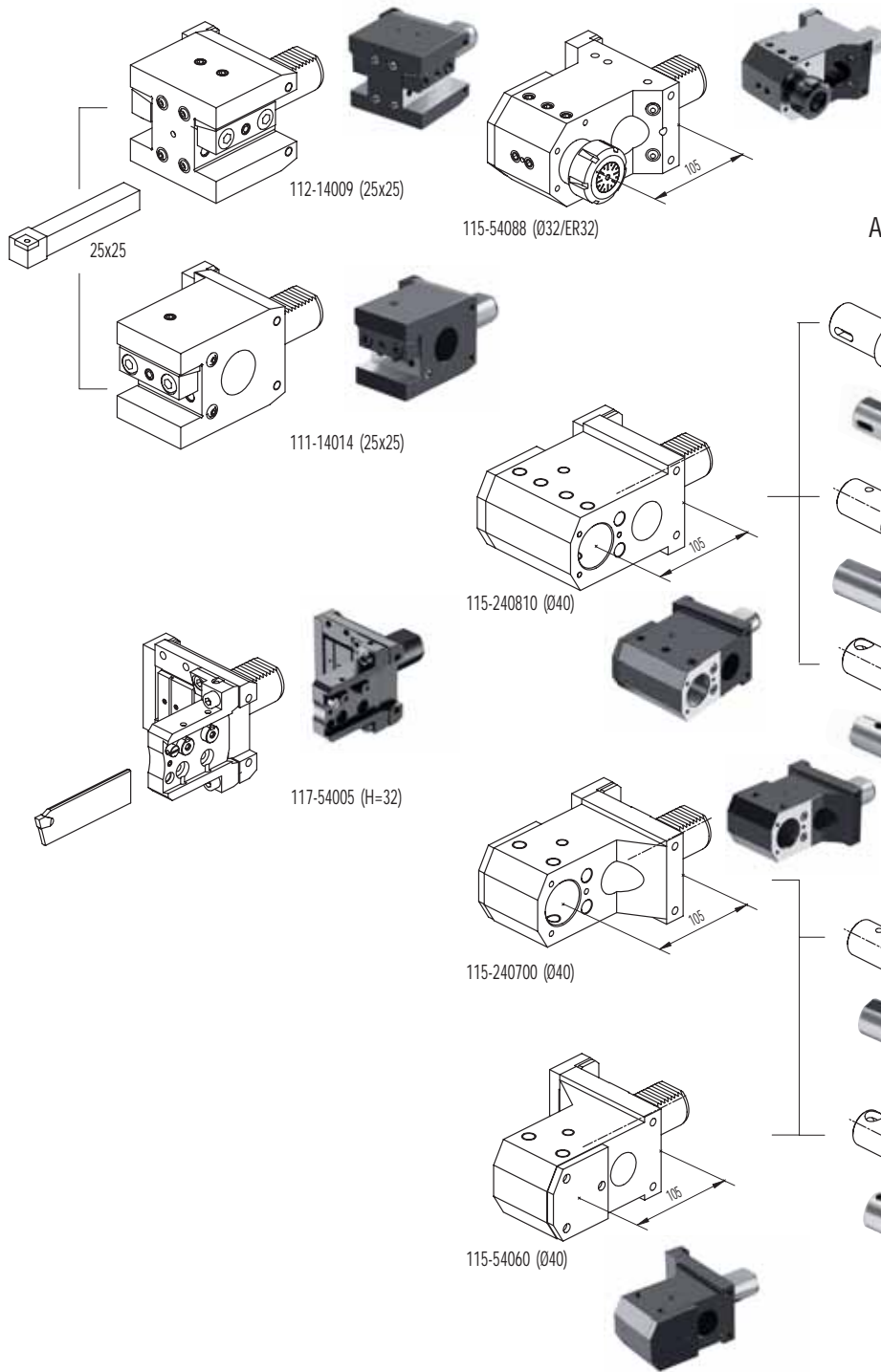

ACCESSORIES

Drill socket
 165-64010 <MT1>
 165-64011 <MT2>
 165-64012 <MT3>

Boring bar sleeve and
 throw-away drill socket
 115-64099 (Ø16 mm)
 165-64001 (Ø20 mm)

Boring bar sleeve and
 throw-away drill socket
 165-64002 (Ø25 mm)
 165-64003 (Ø32 mm)

Boring bar sleeve
 165-64006 (Ø16 mm)
 165-64007 (Ø20 mm)

Boring bar sleeve
 165-64008 (Ø25 mm)
 165-64009 (Ø32 mm)

For turning

ATC Turret (HSK100A) ICTM STANDARD

45°

90°

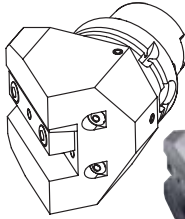

141-11603 25x25 mm

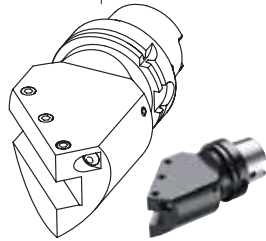

141-11601 25x25 mm

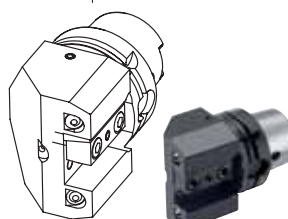

142-11607 25x25 mm

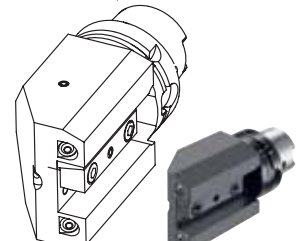

142-11608 25x25 mm

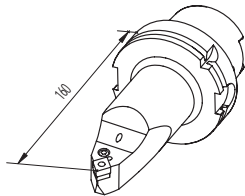

H100APCMNR12-L160

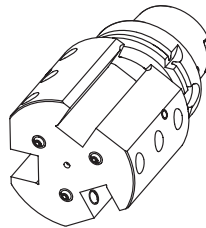

142-21605 25x25 mm

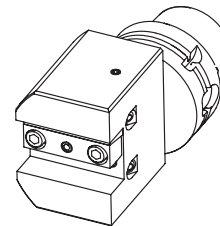

141-11602 25x25 mm

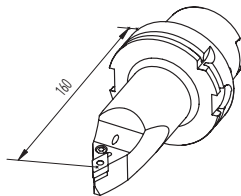

H100APDNNR15-L160

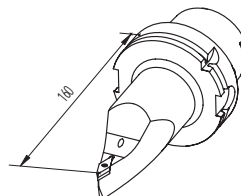

H100ASVVCN16-L160



BORING BAR HOLDER

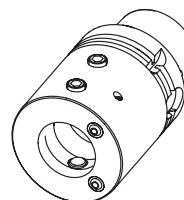

145-21608 Ø50 mm

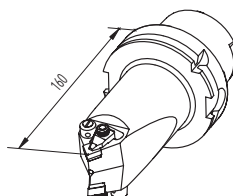

H100ADCM12DDM15-L160



ACCESSORIES

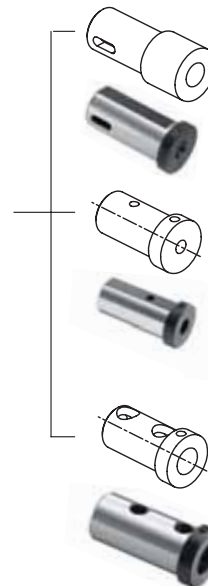
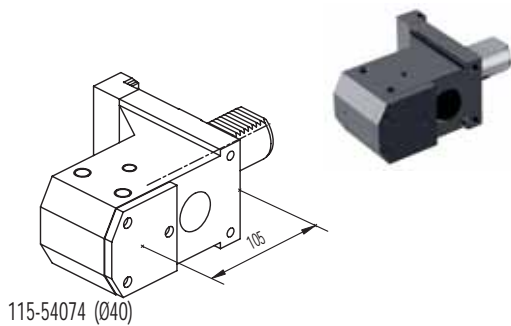
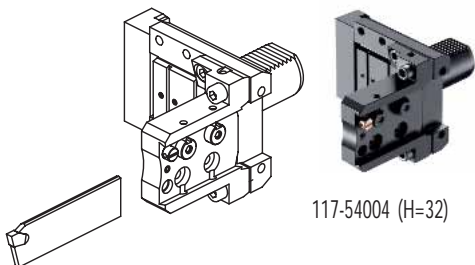
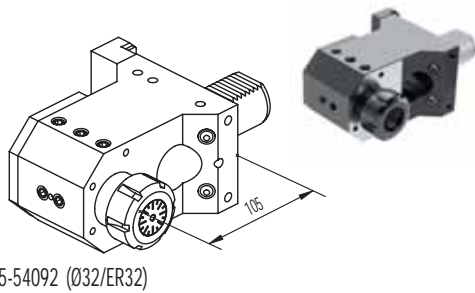
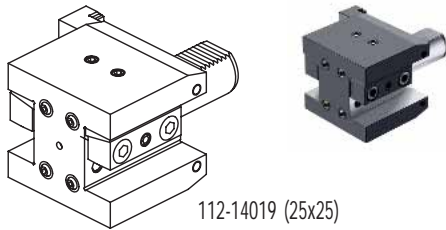

Drill socket
 165-64010 <MT1>
 165-64011 <MT2>
 165-64012 <MT3>

Boring bar sleeve and
 throw-away drill socket
 115-64099 (Ø16 mm)
 165-64001 (Ø20 mm)

Boring bar sleeve and
 throw-away drill socket
 165-64002 (Ø25 mm)
 165-64003 (Ø32 mm)

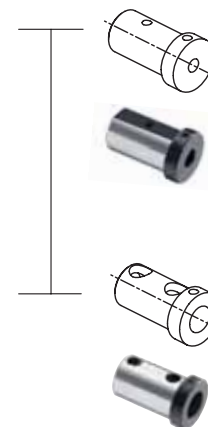

Boring bar sleeve
 165-64124 (Ø10 mm)
 165-64125 (Ø12 mm)
 165-64126 (Ø16 mm)
 165-64127 (Ø20 mm)

Boring bar sleeve
 165-64008 (Ø25 mm)
 165-64009 (Ø32 mm)

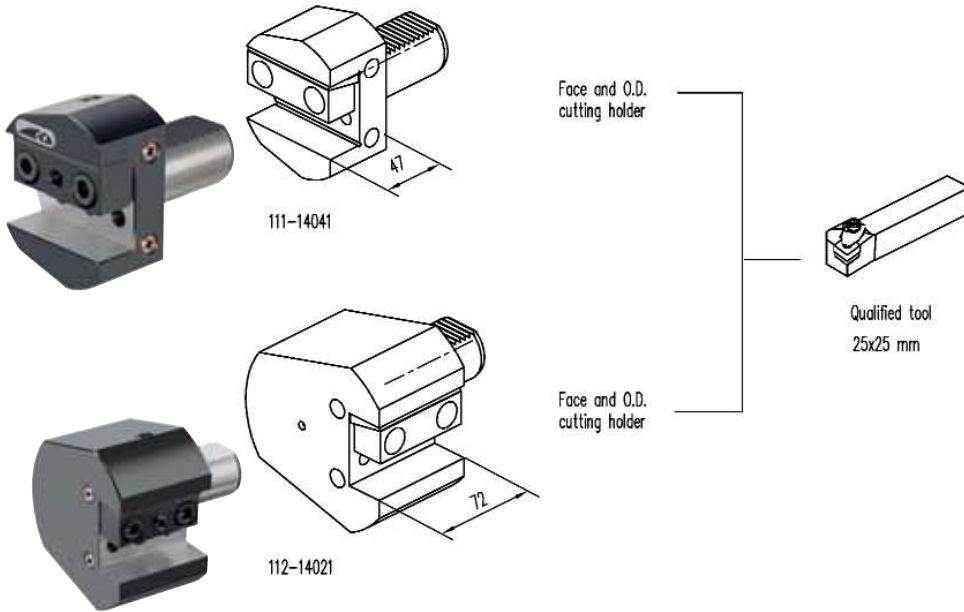

ACCESSORIES

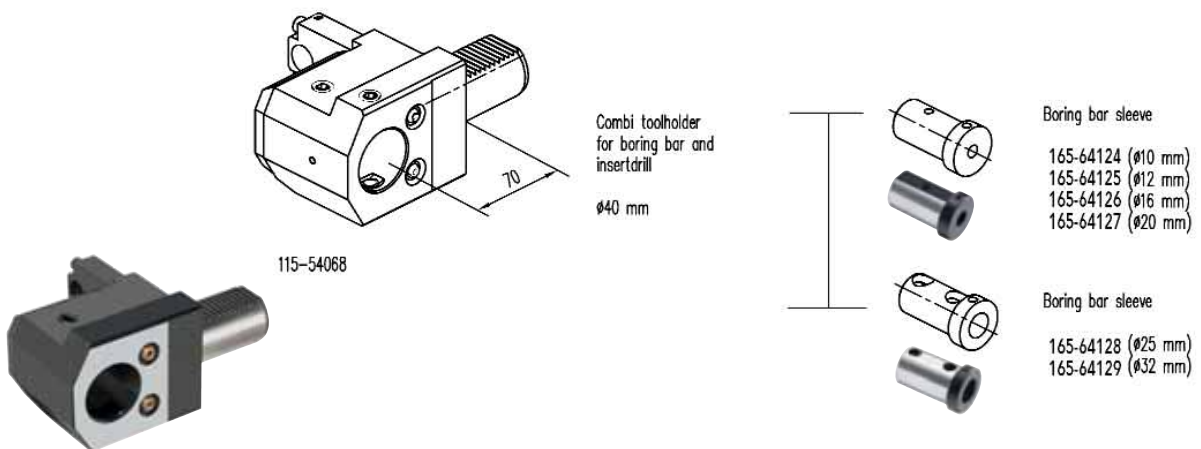

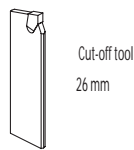
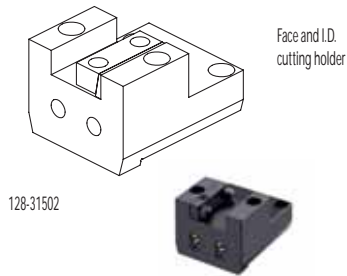
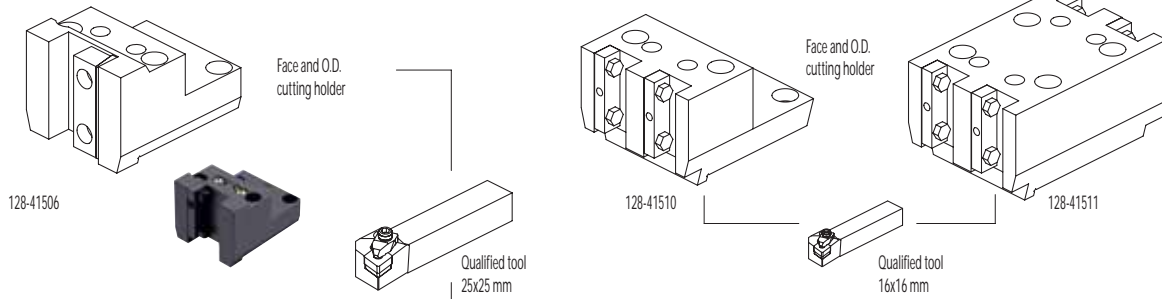

CONNECTION

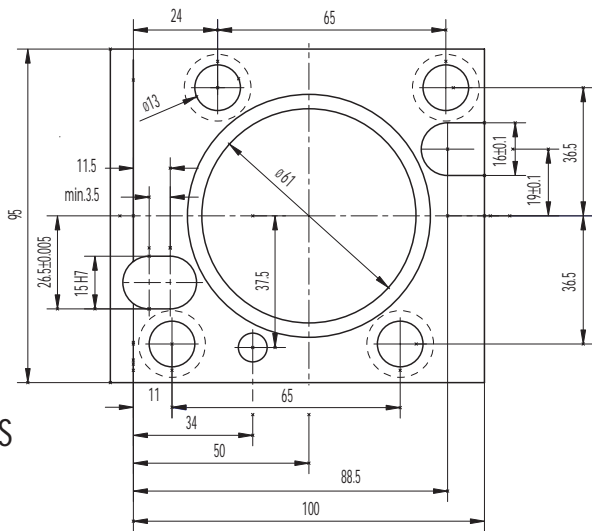

ACCESSORIES

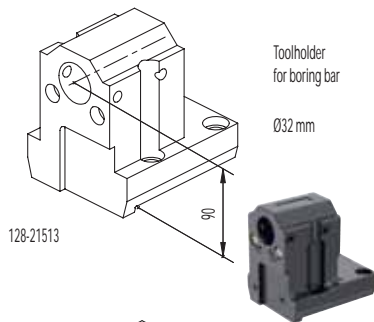

Toolholder for boring bar

$\varnothing 32$ mm

Boring bar sleeve

- 165-63289 (08 mm)
- 165-63290 (010 mm)
- 165-63291 (012 mm)
- 165-63292 (016 mm)

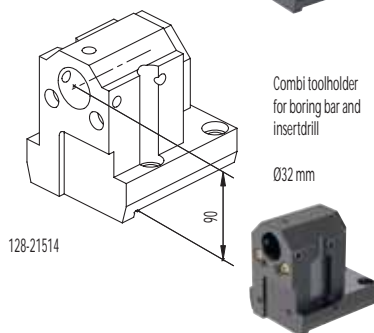

Combi toolholder for boring bar and insert drill

$\varnothing 32$ mm

Boring bar sleeve

- 165-63293 (020 mm)
- 165-63294 (025 mm)

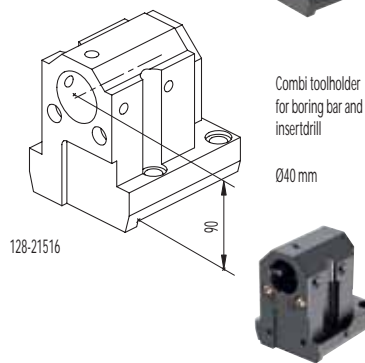
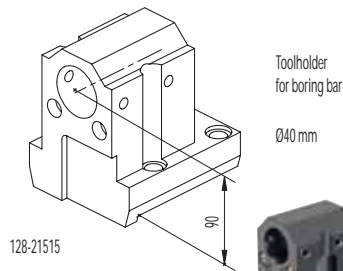
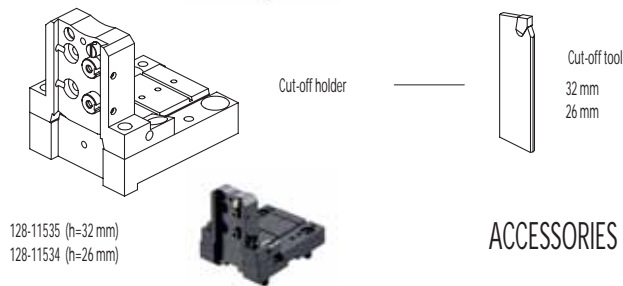
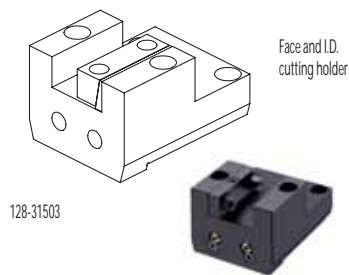
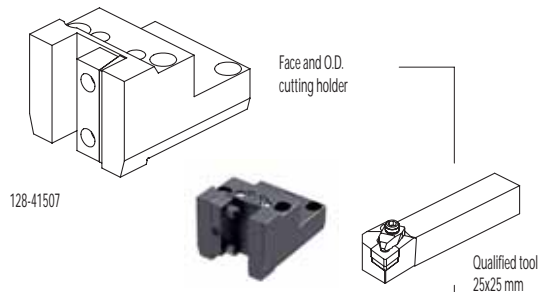

ACCESSORIES

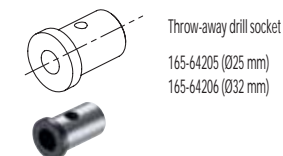
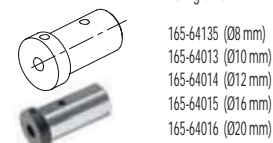

CONNECTION

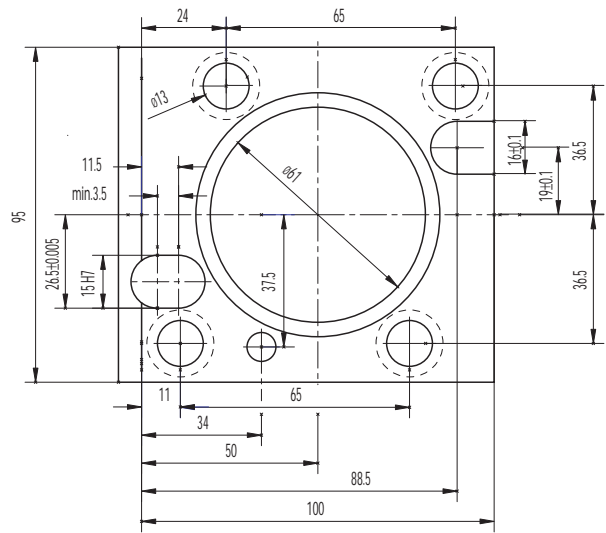

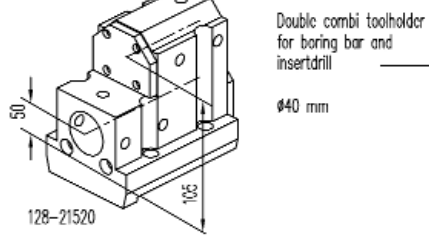
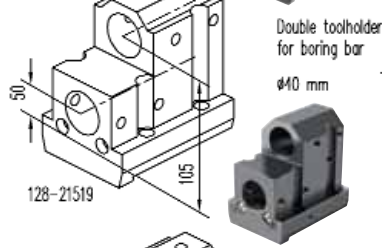
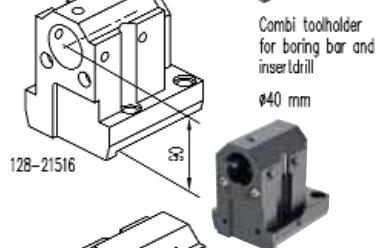
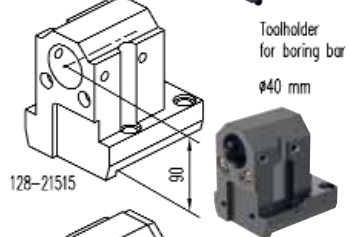
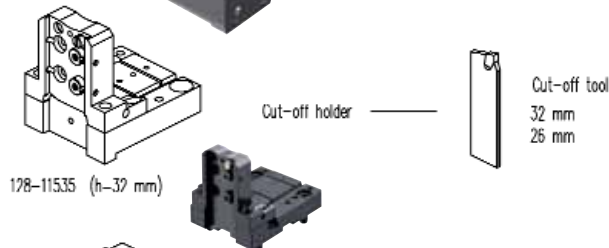
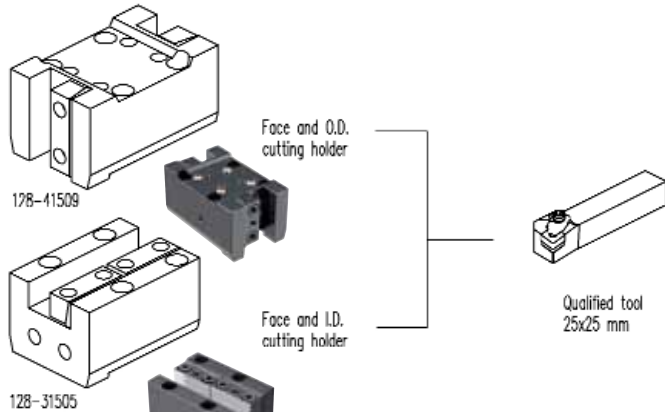

ACCESSORIES

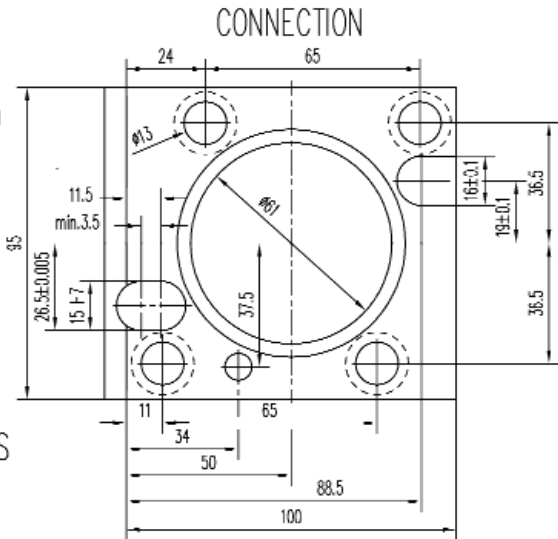
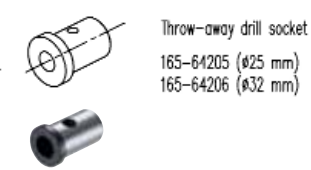
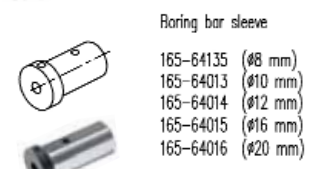

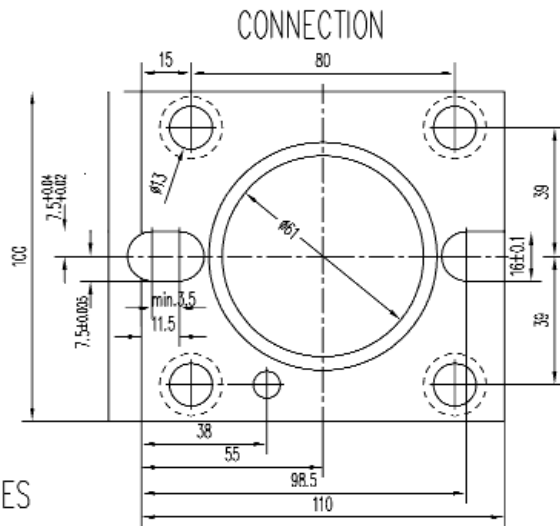
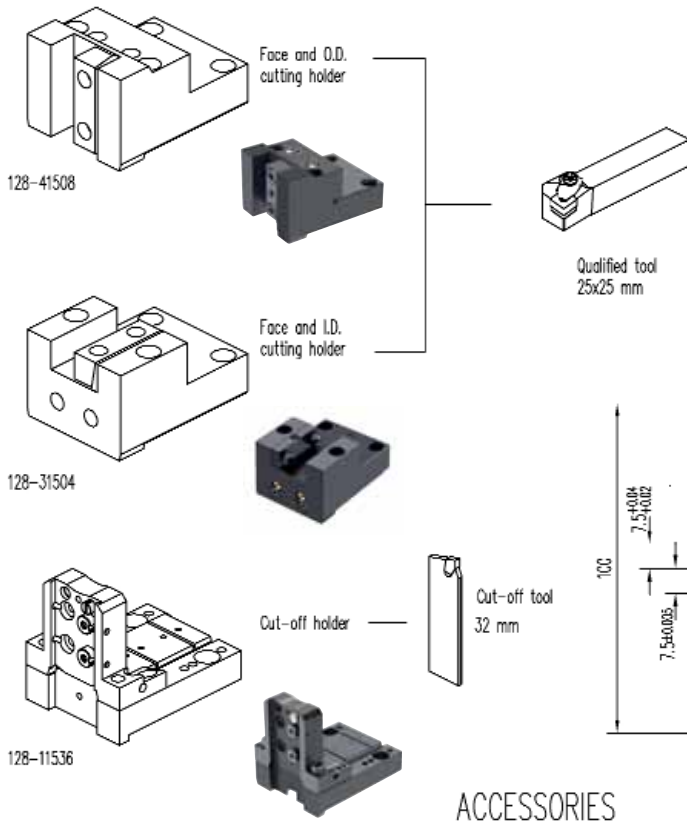

ACCESSORIES

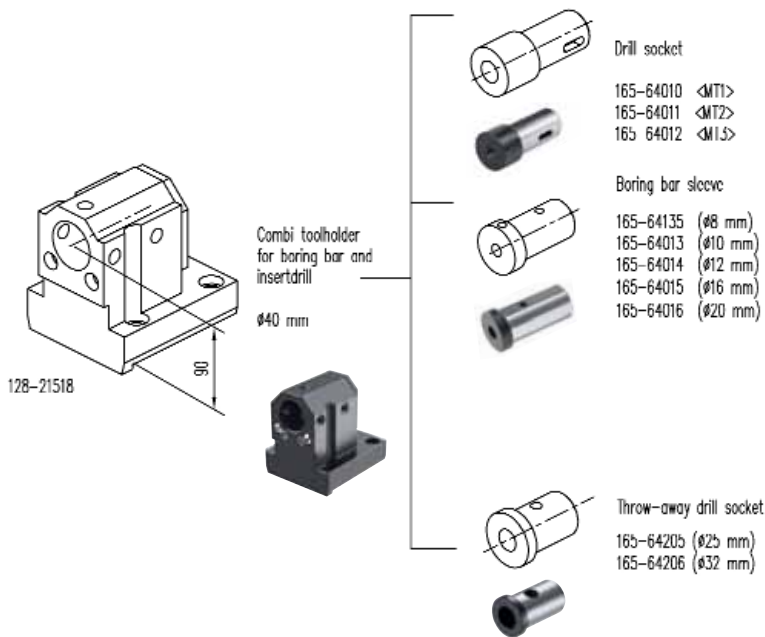

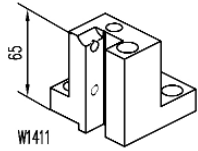

W1411

Face and O.D. cutting holder

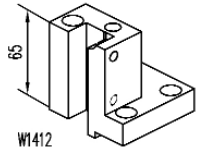

W1412

Face and O.D. cutting holder

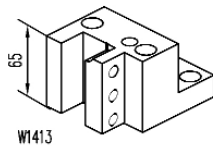

W1413

Face and O.D. cutting holder

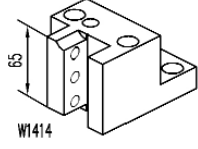

W1414

Face and O.D. cutting holder

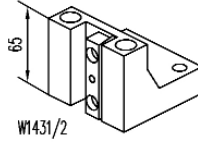

W1431/2

Face and O.D. cutting holder

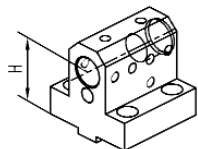

W1417 D25 (H=55 mm)
W4437 D25 (H=75 mm)

Combi toolholder for boring bar and insertdrill

Ø25 mm

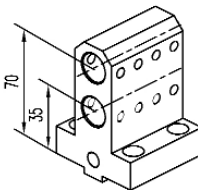

W1418 D25

Double toolholder for boring bar

Ø25 mm

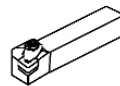

Qualified tool
20x20 mm

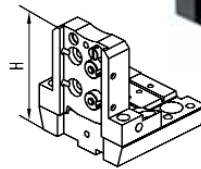

Cut-off holder



Cut-off tool

121-22076 (h=32 mm H=100 mm)

CONNECTION

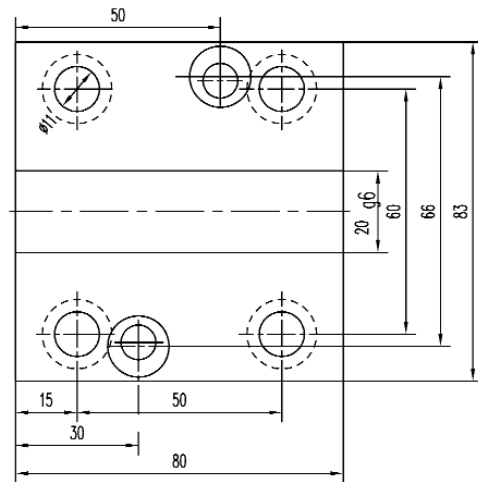

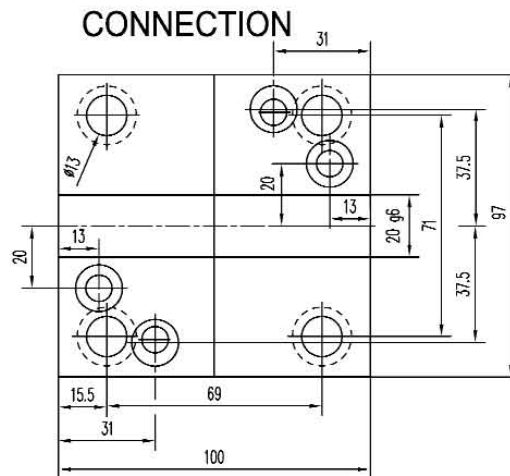
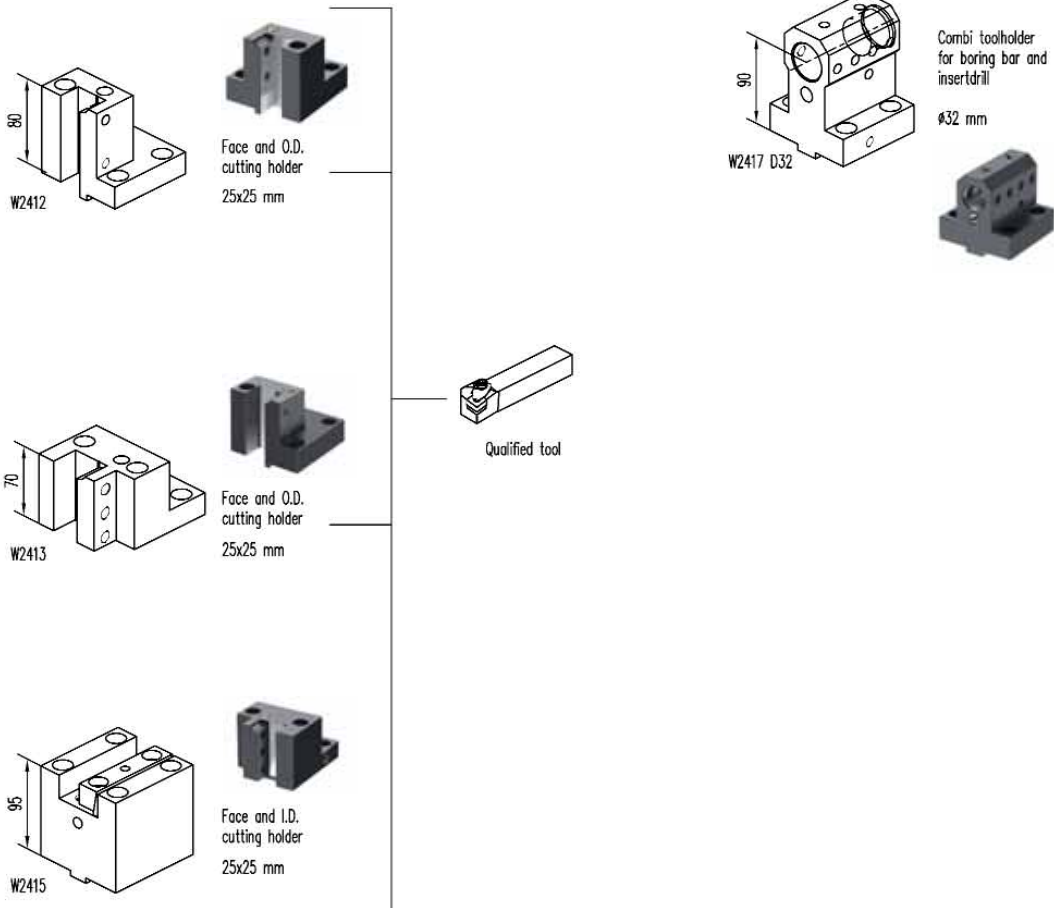

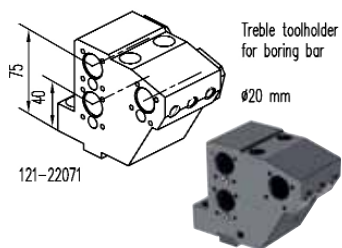
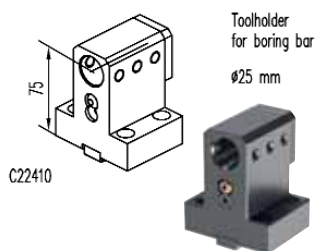
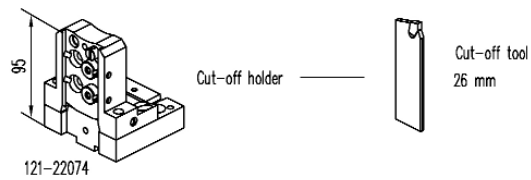
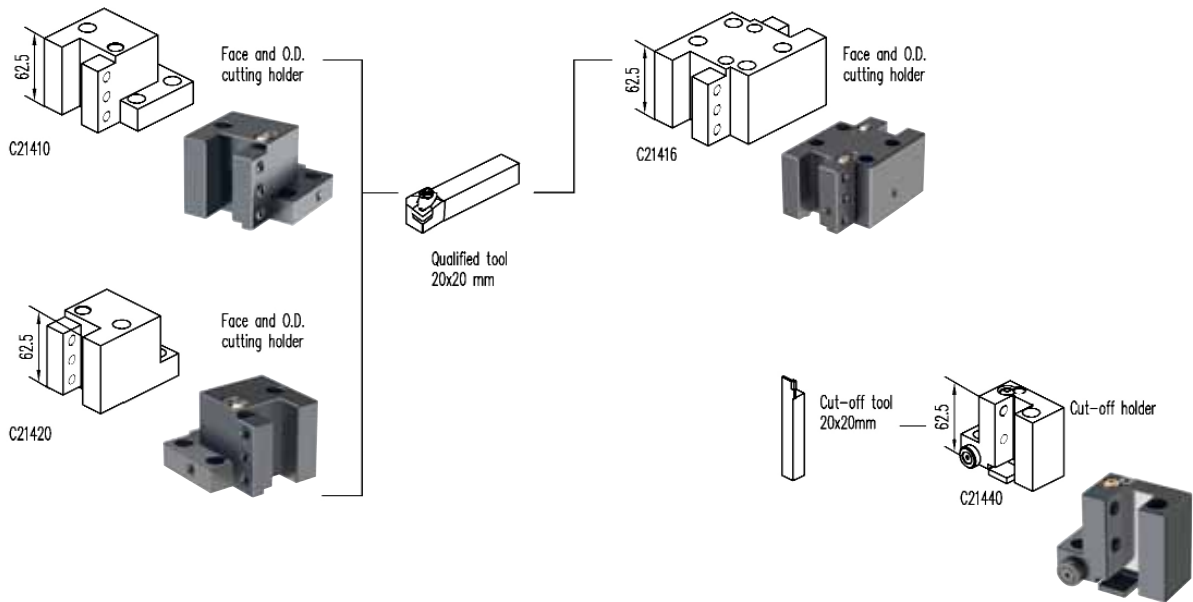

CONNECTION

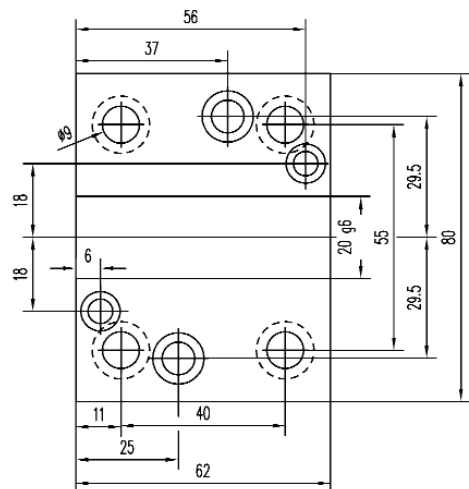

NAKAMURA TOME

WT150 - WTW150 - WTS150
WT250 - SC150 - SC250

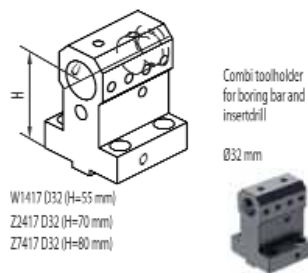
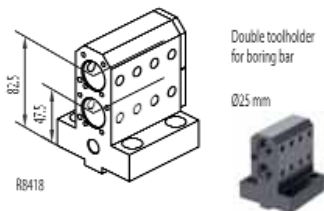
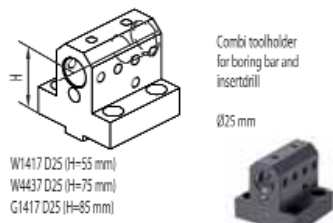
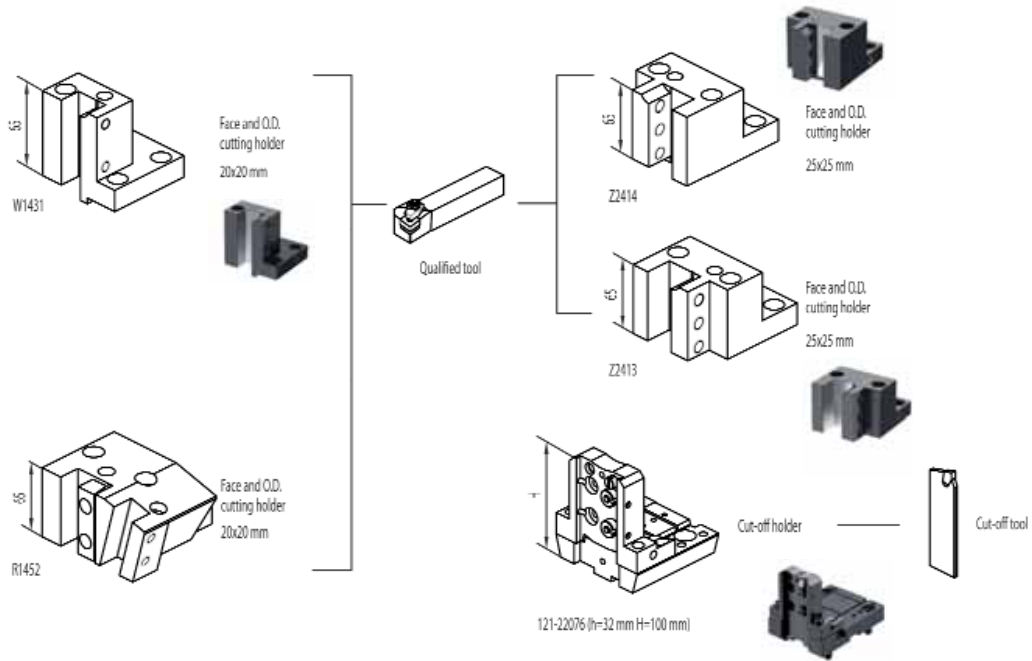

CONNECTION

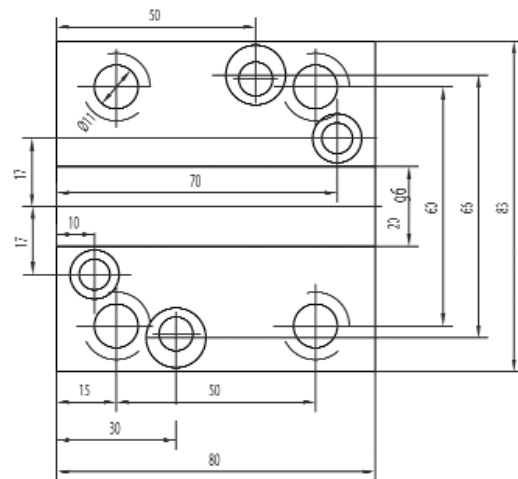

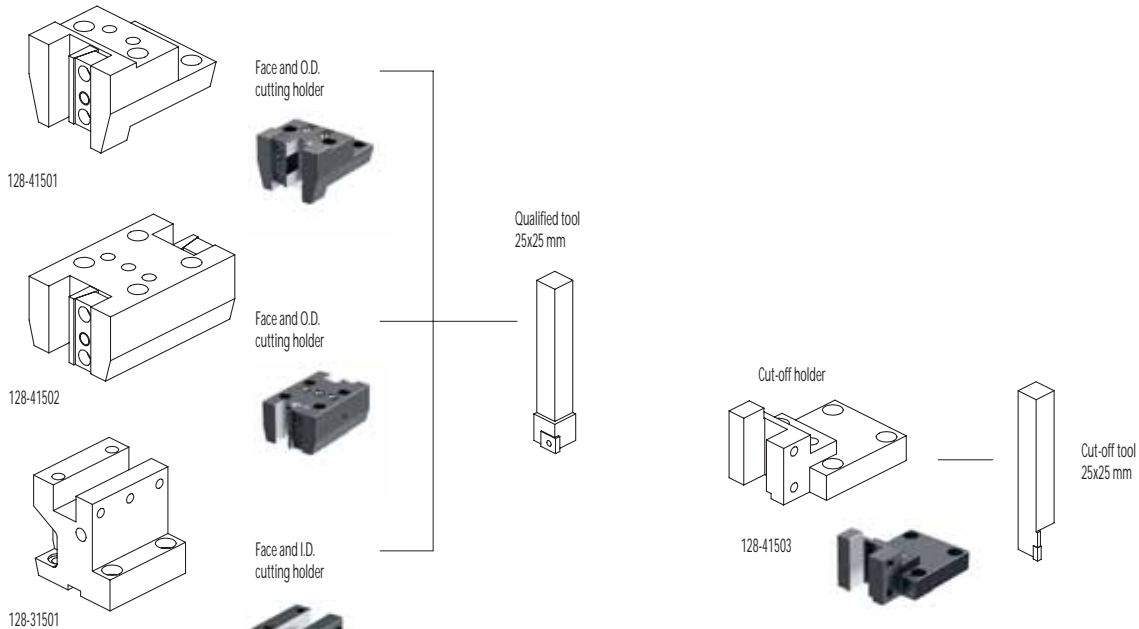

ACCESSORIES

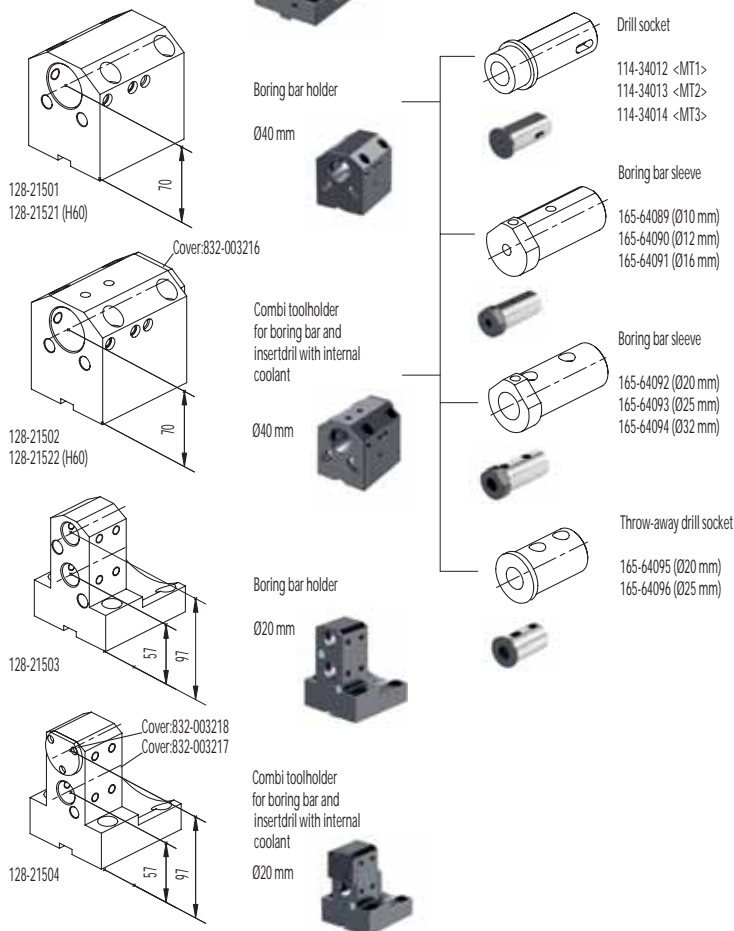

CONNECTION

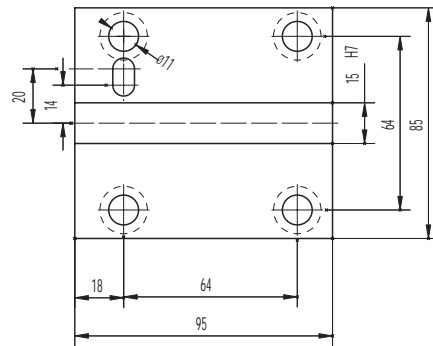

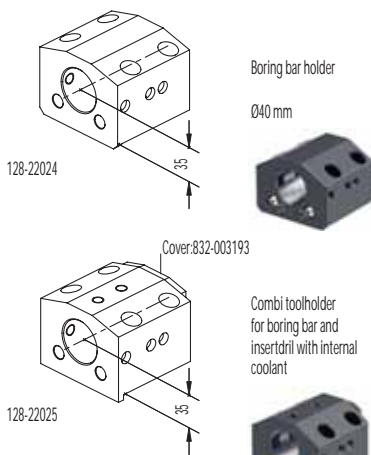
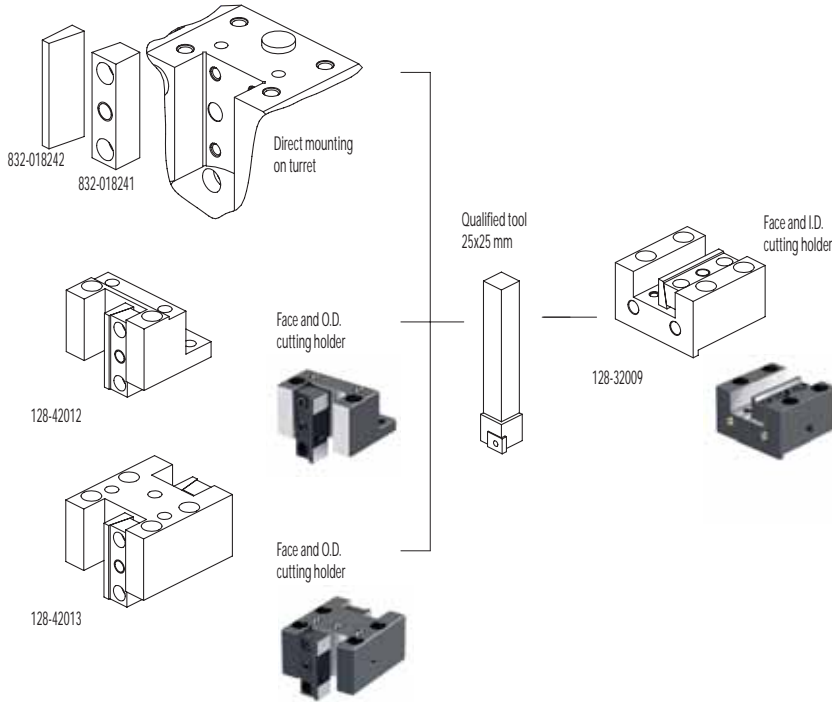

ACCESSORIES

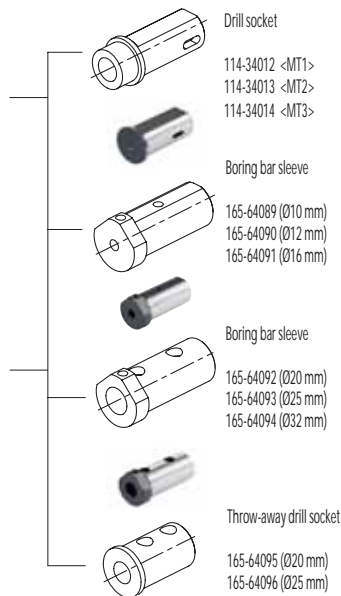

CONNECTION

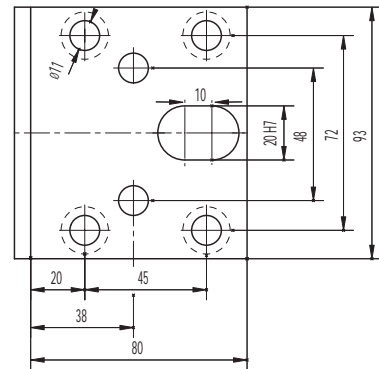

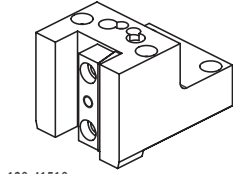

128-41518

Face and O.D.
cutting holder

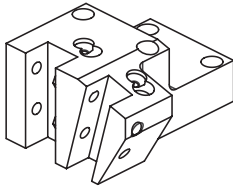

128-41519

Face and O.D.
cutting holder

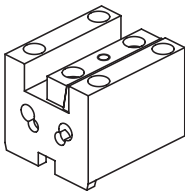

128-31511

Face and O.D.
cutting holder

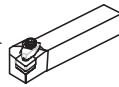

Qualified tool
20x20 mm

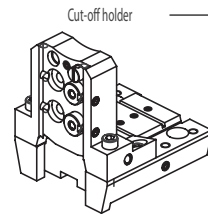

128-11546

Cut-off holder



Cut-off tool
26 mm

ACCESSORIES

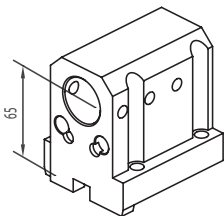

128-21529

Toolholder
for boring bar

Ø32 mm

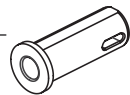

Drill socket

114-33208 <MT1>
114-33209 <MT2>

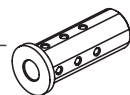

Boring bar sleeve

115-63260 (Ø8 mm)
115-63261 (Ø10 mm)
115-63211 (Ø12 mm)
115-63212 (Ø16 mm)
115-63213 (Ø20 mm)

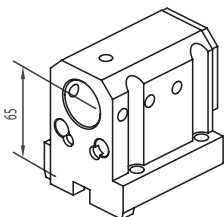

128-21530

Combi toolholder
for boring bar
and insert drill

Ø32 mm

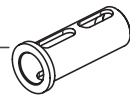

Boring bar sleeve

115-63214 (Ø25 mm)

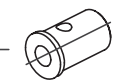

Throw-away drill socket

165-63325 (Ø16 mm)
165-63326 (Ø20 mm)
165-63327 (Ø25 mm)

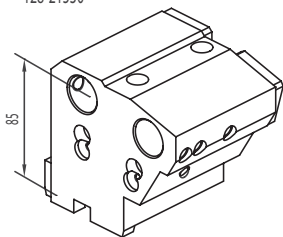

128-21531

Combi toolholder
for boring bar

2xØ25 mm

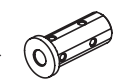

Boring bar sleeve

115-62538 (Ø8 mm)
115-62539 (Ø10 mm)
115-62540 (Ø12 mm)

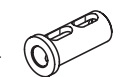

Boring bar sleeve

115-62541 (Ø16 mm)
165-62537 (Ø20 mm)

CONNECTION

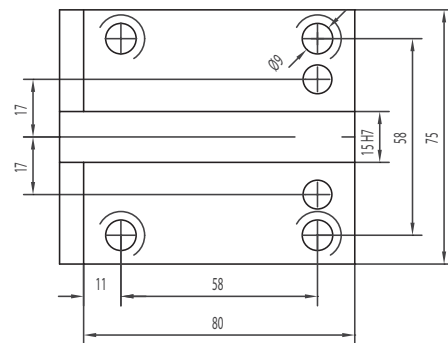

DOOSAN (BMT55)

DOOSAN (BMT55)

PUMA 230-240M/MS - 280LM - 1500-2000-2500M/MS/Y/SY
 2100 SERIE - TT1500-TT1800MS/SY
 TL2000-2500LM - MX1600/2100TS
 LYNX 300M

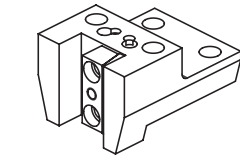

128-41520

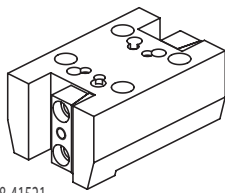

128-41521

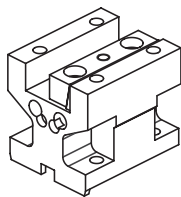

128-31512

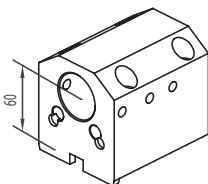

128-21532

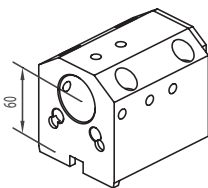

128-21533

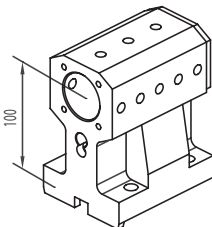

128-21534

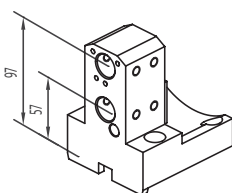

128-21535

Face and O.D.
cutting holder

Face and O.D.
cutting holder

Face and O.D.
cutting holder

Qualified tool
25x25 mm

Face and O.D.
cutting holder

128-41522

Cut-off holder

Cut-off tool
26 mm
32 mm

128-11548 (26 mm)
128-11549 (32 mm)

ACCESSORIES

Toolholder
for boring bar

Ø40 mm

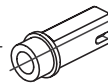

Drill socket

114-34012 <MT1>
114-34013 <MT2>
114-34014 <MT3>

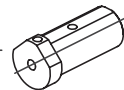

Boring bar sleeve

165-64089 (Ø10 mm)
165-64090 (Ø12 mm)
165-64091 (Ø16 mm)

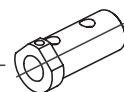

Boring bar sleeve

165-64092 (Ø20 mm)
165-64093 (Ø25 mm)
165-64094 (Ø32 mm)

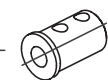

Throw-away drill socket

165-64095 (Ø20 mm)
165-64096 (Ø25 mm)
165-64097 (Ø32 mm)

Combi toolholder
for boring bar
and insertdrill

Ø40 mm

Combi toolholder
for boring bar
and insertdrill

2xØ20 mm

Driven tools

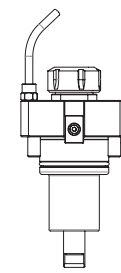

124-05501

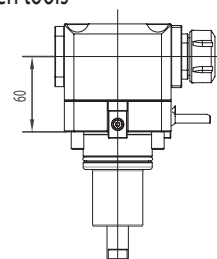

124-05502



CONNECTION

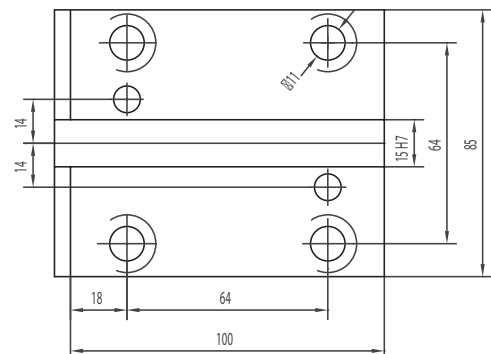

DOOSAN PUMA (BMT65)

300M/MS - V400M - TT2000SY - TT2500SY
TT2500MS - 2600/3100 SERIE
MX2000ST - MX2500T/ST/LST - VT450/TM
INVERTURN 300M

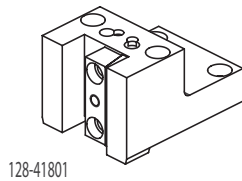

128-41801

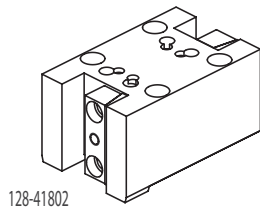

128-41802

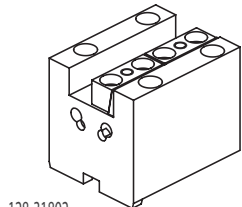

128-31802

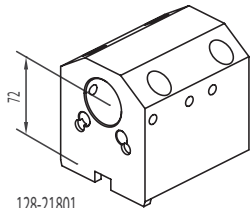

128-21801

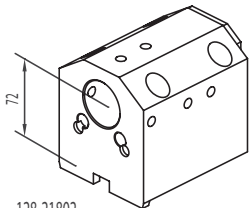

128-21802

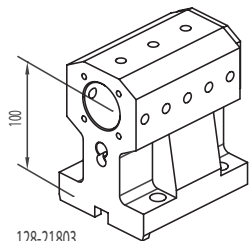

128-21803

Face and O.D.
cutting holder

Face and O.D.
cutting holder

Face and O.D.
cutting holder

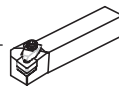

Qualified tool
25x25 mm

Face and O.D.
cutting holder

Face and O.D.
cutting holder

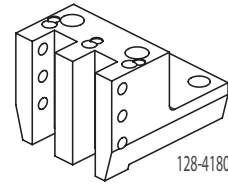

128-41803

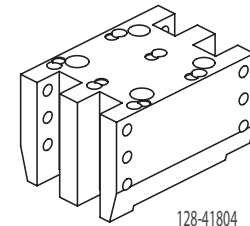

128-41804

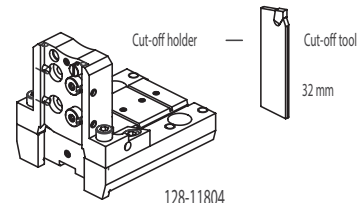

128-11804

ACCESSORIES

Toolholder
for boring bar

Ø40 mm

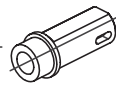

Drill socket

114-34012 <MT1>
114-34013 <MT2>
114-34014 <MT3>

Boring bar sleeve

165-64089 (Ø10 mm)
165-64090 (Ø12 mm)
165-64091 (Ø16 mm)

Combi toolholder
for boring bar
and insert drill

Ø40 mm

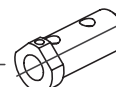
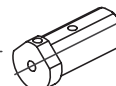

Boring bar sleeve

165-64092 (Ø20 mm)
165-64093 (Ø25 mm)
165-64094 (Ø32 mm)

Throw-away drill socket

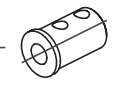

165-64095 (Ø20 mm)
165-64096 (Ø25 mm)
165-64097 (Ø32 mm)

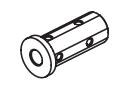

Boring bar sleeve

115-62538 (Ø8 mm)
115-62539 (Ø10 mm)
115-62540 (Ø12 mm)

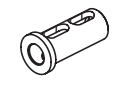

Boring bar sleeve

115-62541 (Ø16 mm)
165-62537 (Ø20 mm)

Driven tools

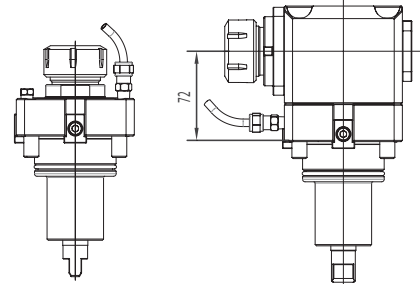

124-06501

124-06502



CONNECTION

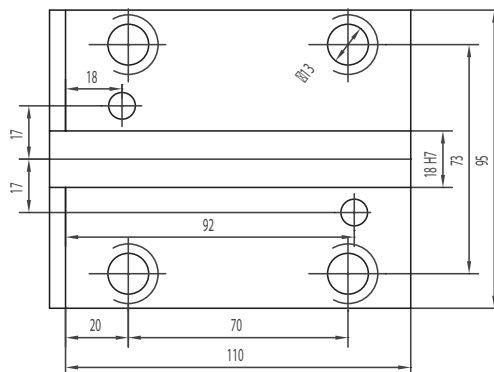

DOOSAN PUMA (BMT75)

400 - 480M/LM/XLM - VT 750M/TM

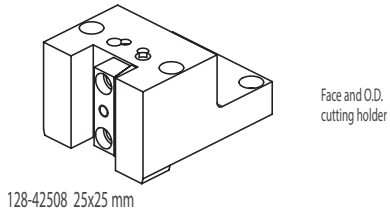

Face and O.D. cutting holder

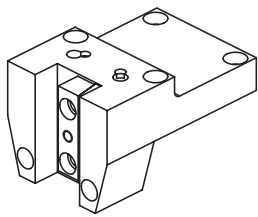

Face and O.D. cutting holder

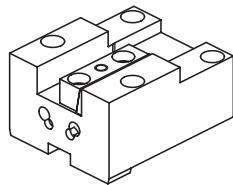

Face and O.D. cutting holder

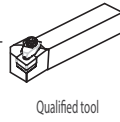

CONNECTION

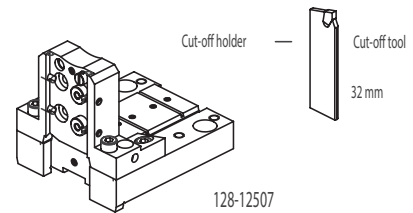
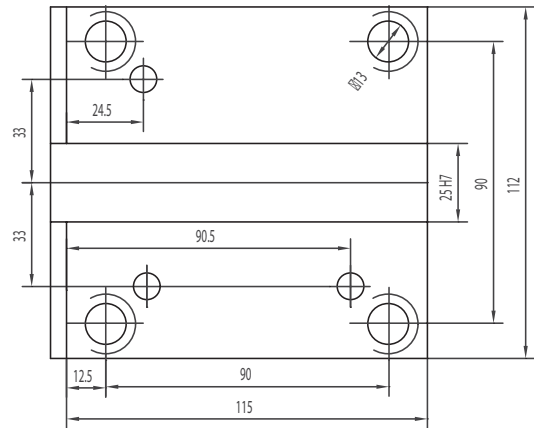

ACCESSORIES

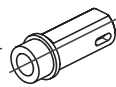
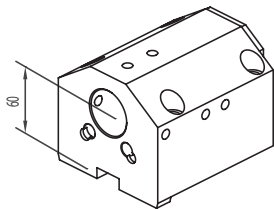

114-34012 <MT1>
114-34013 <MT2>
114-34014 <MT3>

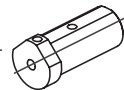

165-64089 ($\varnothing 10$ mm)
165-64090 ($\varnothing 12$ mm)
165-64091 ($\varnothing 16$ mm)

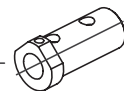

165-64092 ($\varnothing 20$ mm)
165-64093 ($\varnothing 25$ mm)
165-64094 ($\varnothing 32$ mm)

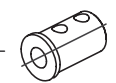

165-64095 ($\varnothing 20$ mm)
165-64096 ($\varnothing 25$ mm)
165-64097 ($\varnothing 32$ mm)

Driven tools

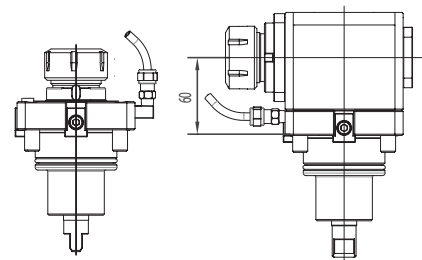

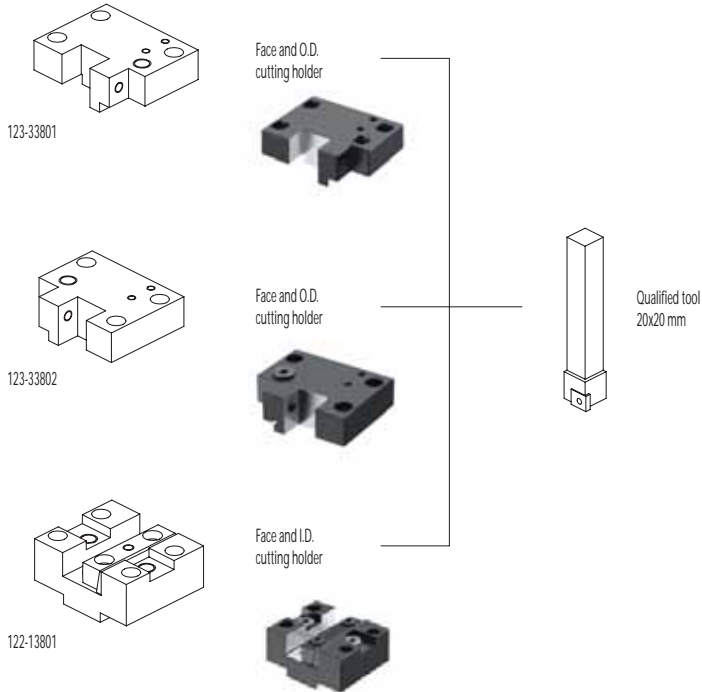

CONNECTION

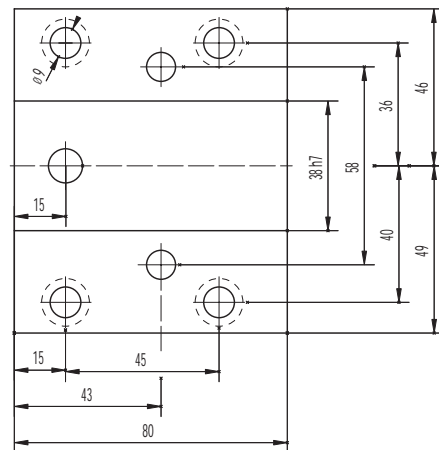

ACCESSORIES

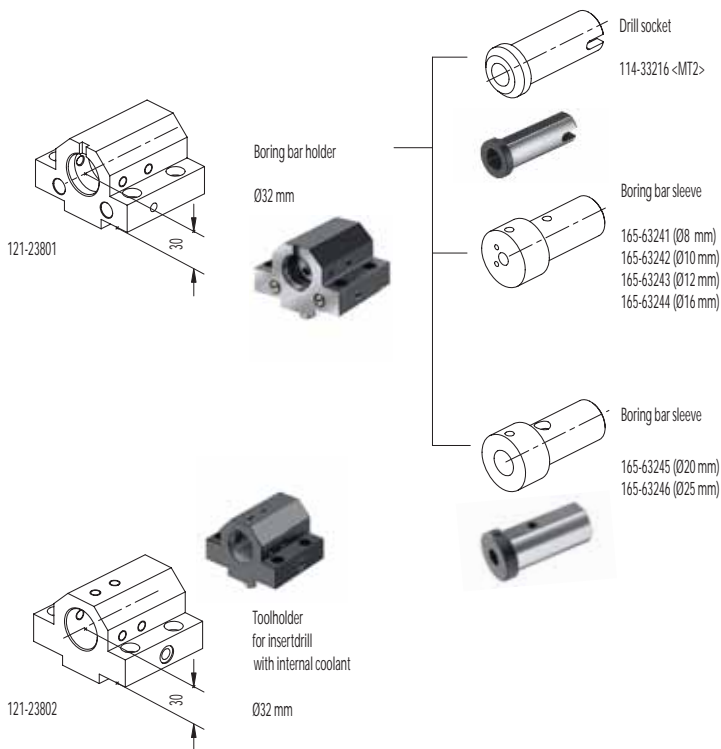

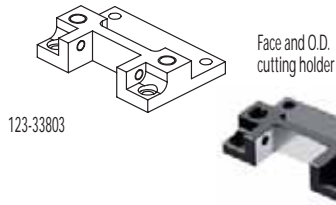

Face and O.D. cutting holder



Face and I.D. cutting holder

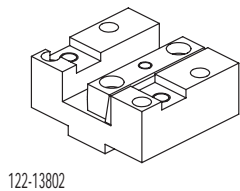

Qualified tool
25x25 mm

CONNECTION

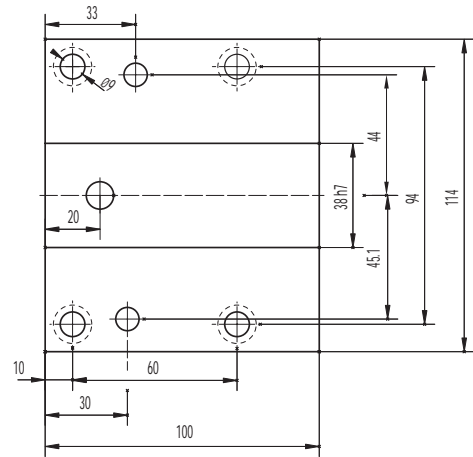

ACCESSORIES

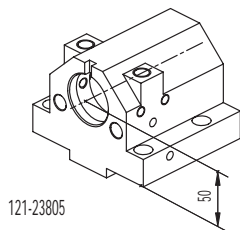

Boring bar holder
Ø40 mm

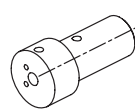

Boring bar sleeve

- 165-64114 (Ø8 mm)
- 165-64115 (Ø10 mm)
- 165-64116 (Ø12 mm)
- 165-64117 (Ø16 mm)
- 165-64118 (Ø20 mm)

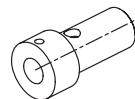

Boring bar sleeve

- 165-64119 (Ø25 mm)
- 165-64120 (Ø32 mm)

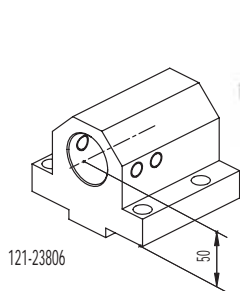

Toolholder for insertdrill with internal coolant
Ø40 mm

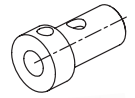
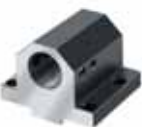

Throw-away drill socket

- 165-64121 (Ø20 mm)
- 165-64122 (Ø25 mm)
- 165-64123 (Ø32 mm)



MAZAK SQT MAZAK QTN (VDI40)

SQT 15, SQT 18 M / MS - 12 Stations
SQT 200, SQT 250 M / MS - 12 Stations
QTN 200, QTN 250 M / MS / MY / MSY - 12 Stations

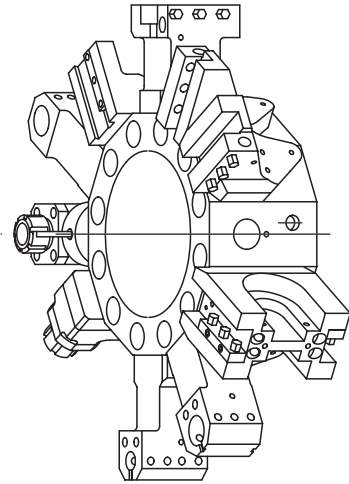
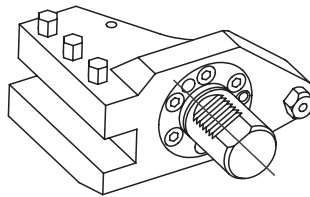
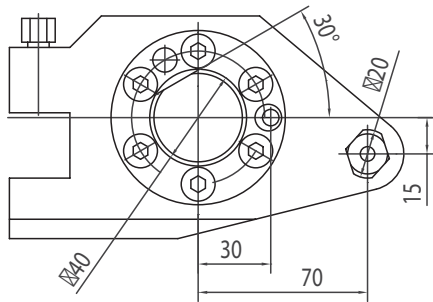

Qualified tool
25x25 mm

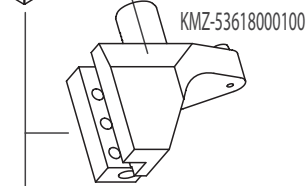
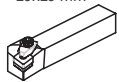

KMZ-53618000100

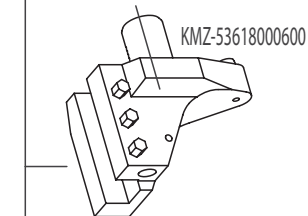

KMZ-53618000600

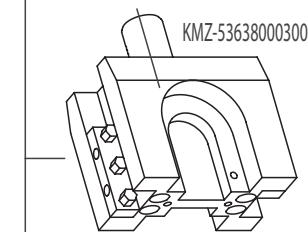

KMZ-53638000300

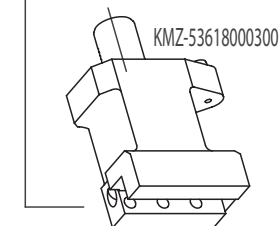

KMZ-53618000300

ACCESSORIES

Drill socket

- 114-34015 <MT1>
- 114-34016 <MT2>
- 114-34017 <MT3>

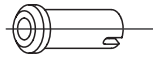

Boring bar sleeve

- 165-64114 (Ø8 mm)
- 165-64115 (Ø10 mm)
- 165-64116 (Ø12 mm)
- 165-64117 (Ø16 mm)
- 165-64118 (Ø20 mm)



Boring bar sleeve

- 165-64119 (Ø25 mm)
- 165-64120 (Ø32 mm)



Throw-away drill socket

- 165-64121 (Ø20 mm)
- 165-64122 (Ø25 mm)
- 165-64123 (Ø32 mm)



Cut-off tool
32 mm

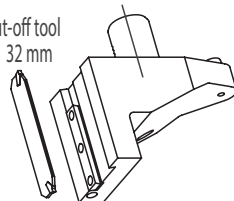

KMZ-53618000400

KMZ-53208005100

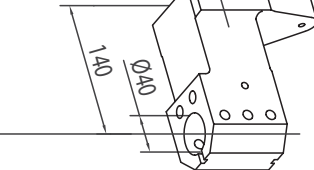

KMZ-53638000400

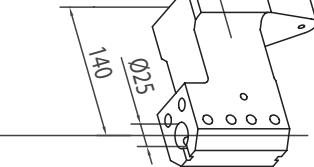

KMZ-53208005200

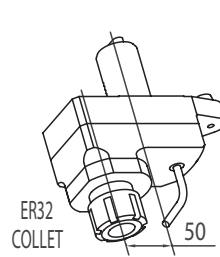
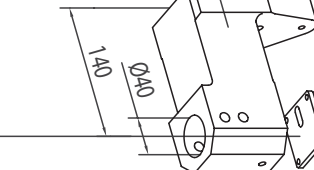

ER32
COLLET

124-54020

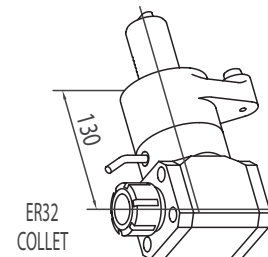

ER32
COLLET

116-54019



ICTM STANDARD



H100APCLNL/R16



H100APDJNL/R15

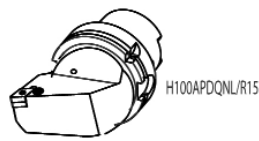

H100APDQNL/R15



H100APSRNI /R19

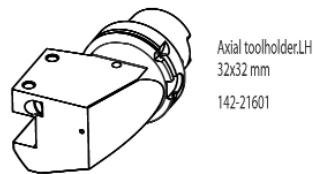

Axial toolholder.LH
32x32 mm
142-21601

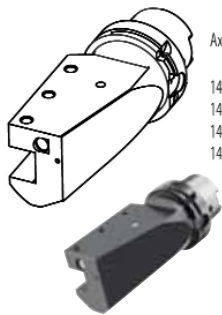

Axial toolholder long
142-21604 (25x25 mm,left)
142-11603 (25x25 mm,right)
142-21603 (32x32 mm,left)
142-11604 (32x32 mm,right)

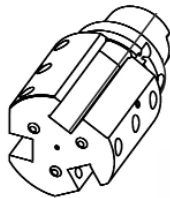

Axial toolholder
25x25 mm
142-21605 (left)
142-11605 (right)

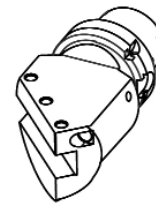

Toolholder 45°
25x25 mm
141-11601

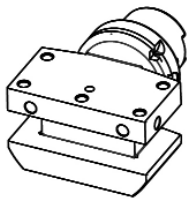

Toolholder with multiple seats
32x32 mm
143-11601

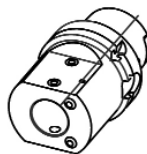

Boring bar holder
Ø40 mm
145-21605

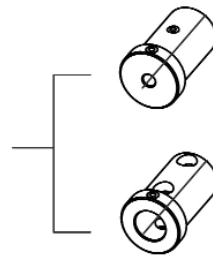

Boring bar sleeve
165-64124 (Ø10 mm)
165-64125 (Ø12 mm)
165-64126 (Ø16 mm)
165-64127 (Ø20 mm)



Boring bar sleeve
165-64128 (Ø25 mm)
165-64129 (Ø32 mm)



832-018722 (25 mm)
832-018732 (20 mm)
832-018721 (25 mm)
832-018731 (20 mm)

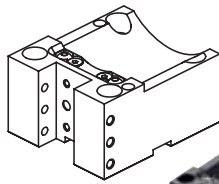

KMS-T00186 (25x25 mm)
KMS-T00187 (20x20 mm)

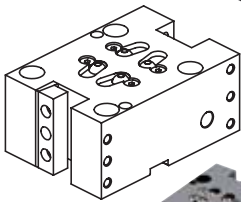

KMS-T00184 (25x25 mm)
KMS-T00185 (20x20 mm)

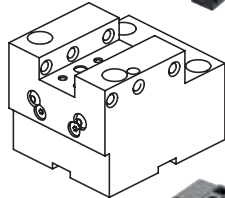

KMS-T03005 (25x25 mm)
KMS-T03006 (20x20 mm)

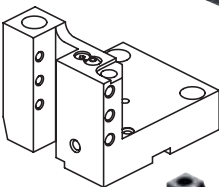

KMS-T00197 (25x25 mm)

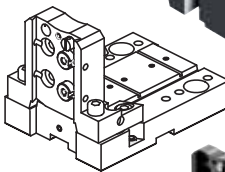

137-00092 (32 mm)

CONNECTION

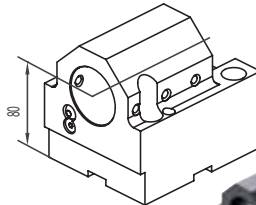
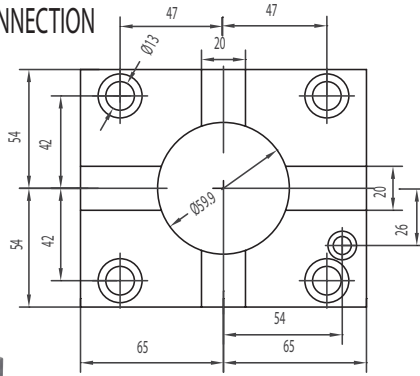

KMS-T10097 (Ø40 mm)
KMS-T10098 (Ø50 mm)

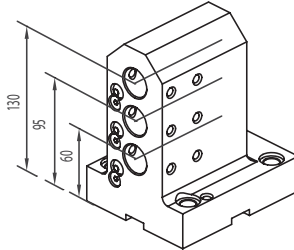

KMS-T10104 (Ø25 mm)

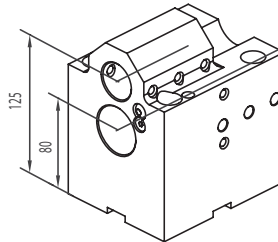

KMS-T10096 (Ø32 mm)

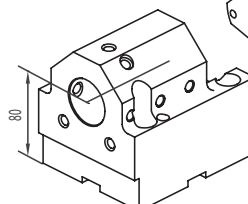

KMS-T13128 (Ø40 mm) with internal coolant

Driven tools

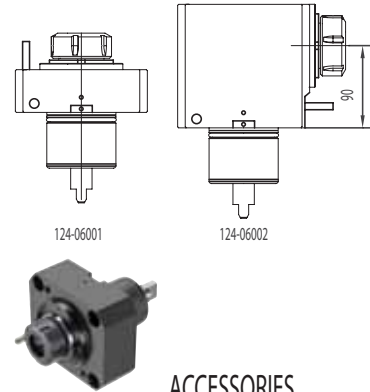

ACCESSORIES

KMS-T20098-A (Ø32 mm)
KMS-T20096-A (Ø25 mm)
KMS-T20094-A (Ø20 mm)
KMS-T20092-A (Ø16 mm)
KMS-T20090-A (Ø12 mm)
KMS-T20088-A (Ø10 mm)
KMS-T20086-A (Ø8 mm)

KMS-T20196-A (Ø20 mm)
KMS-T20194-A (Ø16 mm)
KMS-T20110-A (Ø12 mm)
KMS-T20108-A (Ø10 mm)
KMS-T20106-A (Ø8 mm)

KMS-T22042-A (MT3)
KMS-T22044-A (MT4)
KMS-T22046-A (MT2)
KMS-T22066-A (MT1)

KMS-T20188 (Ø20 mm)
KMS-T20186 (Ø16 mm)
KMS-T20184 (Ø12 mm)
KMS-T20182 (Ø10 mm)
KMS-T20180 (Ø8 mm)

KMS-T20122-A (Ø25 mm)
KMS-T20120-A (Ø20 mm)
KMS-T20118-A (Ø16 mm)
KMS-T20116-A (Ø12 mm)
KMS-T20114-A (Ø10 mm)
KMS-T20112-A (Ø8 mm)

KMS-T20100-A (Ø32 mm)
KMS-T20102-A (Ø25 mm)
KMS-T20104-A (Ø20 mm)
KMS-T20190-A (Ø16 mm)



PRODOTTI A RICHIESTA ARTICLES ON ENQUIRY

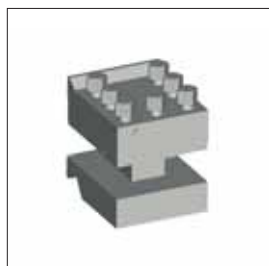
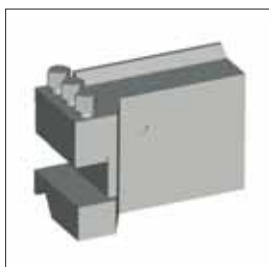
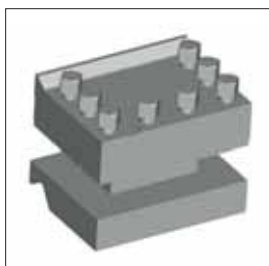
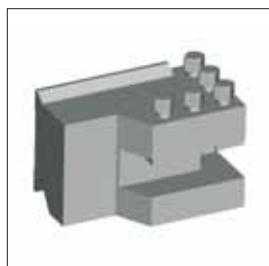

DIN 69881 VDI 3425/3



WERKZEUGHALTER MIT PRISMA
DIN69881 VDI 3425/3



TOOLHOLDER WITH DOVE TAIL CLAMP
DIN69881 VDI3425/3



РЕЗЦЕДЕРЖАТЕЛИ ДЛЯ ТОКАРНЫХ
СТАНКОВ С ЧПУ DIN69881 VDI3425/3



PORTE-OUTIL PRISMATIQUE
DIN69881 VDI3425/3



PORTAUTENSILI PRISMATICI
DIN69881 VDI 3425/3



数控车床刀柄
DIN69881 VDI3425/3

