

KAMATEK

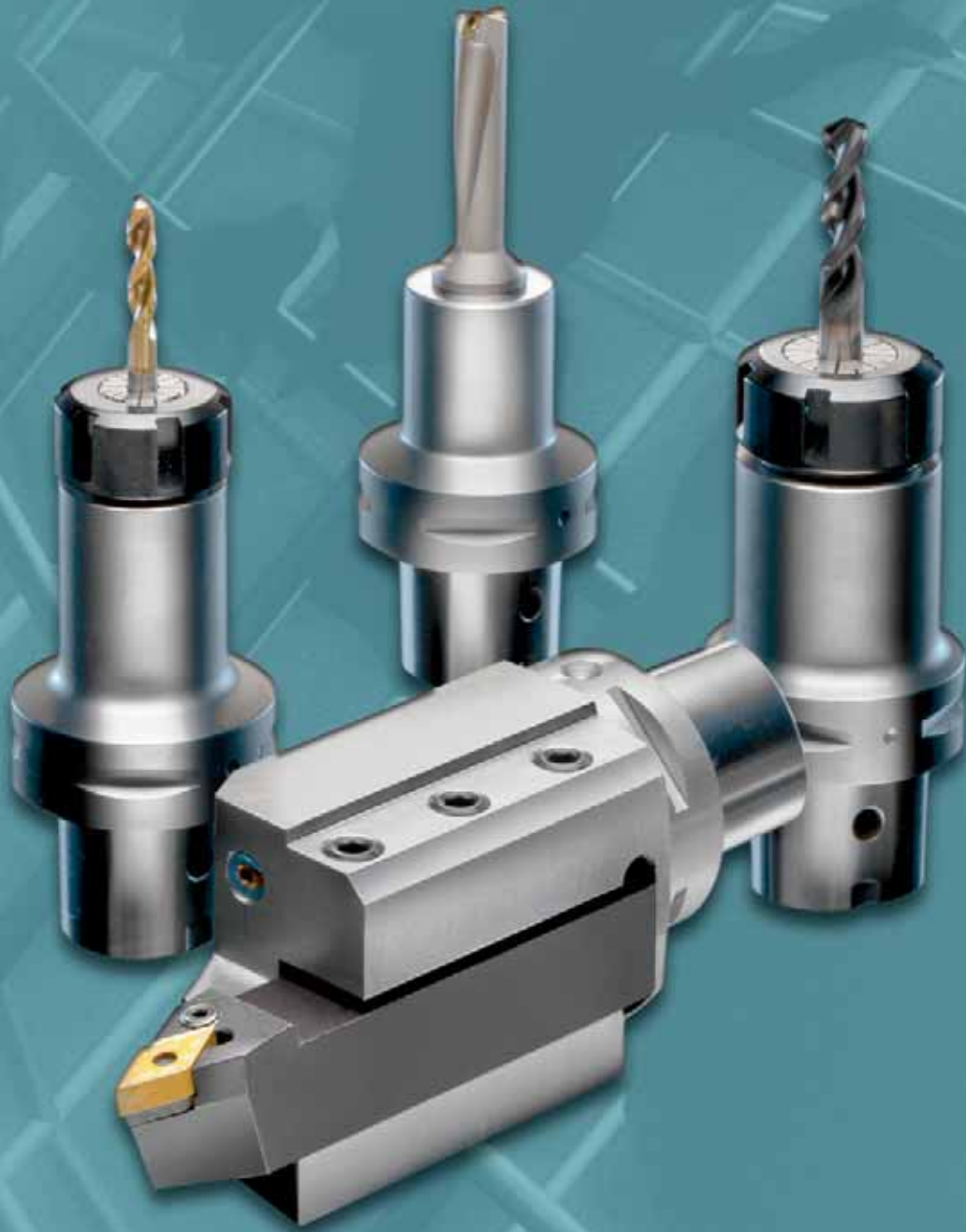

**TOOLHOLDERS
DIN ISO 26623-1**



SPANNZANGENFUTTER MIT POLYGONSCHAFT PORTE-PINCES AVEC ATTACHEMENT POLYGONALE
 POLYGONAL ER COLLET CHUCK PORTAPINZE TIPO ER CON ATTACCO POLIGONALE
 ЦАНГОВЫЕ ПАТРОНЫ С ПОЛИГОНАЛЬНЫМ ХВОСТОВИКОМ 多边形ER筒夹

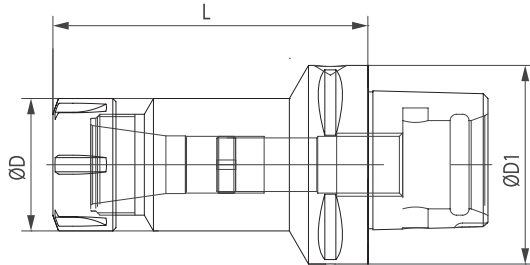

Code N.	Attacco Shank	per pinza for collet	D1 mm	D mm	L mm
C40H60ER16	C40	ER16	40	28	60
C40H60ER20	C40	ER20	40	34	60
C40H60ER25	C40	ER25	40	42	60
C40H60ER32	C40	ER32	40	50	60
C50H60ER16	C50	ER16	50	28	60
C50H60ER20	C50	ER20	50	34	60
C50H60ER25	C50	ER25	50	42	60
C50H60ER32	C50	ER32	50	50	60
C50H65ER40	C50	ER40	50	63	65
C50H100ER16	C50	ER16	50	28	100
C50H100ER20	C50	ER20	50	34	100
C50H100ER25	C50	ER25	50	42	100
C50H100ER32	C50	ER32	50	50	100
C50H100ER40	C50	ER40	50	63	100
C63H60ER16	C63	ER16	63	28	60
C63H60ER20	C63	ER20	63	34	60
C63H60ER25	C63	ER 25	63	42	60
C63H60ER32	C63	ER 32	63	50	60
C63H70ER40	C63	ER40	63	63	70
C63H100ER16	C63	ER 16	63	28	100
C63H100ER20	C63	ER20	63	34	100
C63H100ER25	C63	ER 25	63	42	100
C63H100ER32	C63	ER 32	63	50	100
C63H130ER40	C63	ER 40	63	63	130
C80H70ER25	C80	ER25	80	42	70
C80H70ER32	C80	ER32	80	50	160
C80H70ER40	C80	ER40	80	63	160

MINI NUT VERSION

C63H60ER16M	C63	ER16	63	22	60
C63H100ER16M	C63	ER16	63	22	100
C63H60ER20M	C63	ER20	63	28	60
C63H100ER20M	C63	ER20	63	28	100

WELDON SPANNFUTTER MIT POLYGONSCHAFT
 POLYGONAL END MILL HOLDER WELDON
 ПАТРОНЫ EPS ДЛЯ КОНЦЕВЫХ ФРЕЗ С ХВОСТОВИКОМ WELDON

PORTE-FRAISES WELDON AVEC ATTACHEMENT POLYGONALE
 PORTAFRESE WELDON CON ATTACCO POLIGONALE
 多边形威尔登式铣刀柄

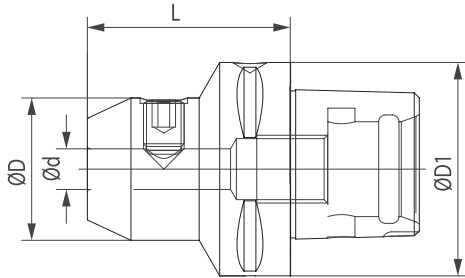

Code N.	Attacco Shank	D1 mm	D mm	d mm	L mm
C40H50WE06	C40	40	25	6	50
C40H50WE08	C40	40	28	8	50
C40H50WE10	C40	40	35	10	50
C40H55WE12	C40	40	42	12	55
C40H55WE14	C40	40	44	14	55
C40H55WE16	C40	40	48	16	55
C50H55WE06	C50	50	25	6	55
C50H55WE08	C50	50	28	8	55
C50H65WE10	C50	50	35	10	65
C50H65WE12	C50	50	42	12	65
C50H65WE14	C50	50	42	14	65
C50H65WE16	C50	50	48	16	65
C50H65WE18	C50	50	48	18	65
C50H65WE20	C50	50	52	20	65
C50H80WE25	C50	50	65	25	80
C63H55WE06	C63	63	25	6	55
C63H55WE08	C63	63	28	8	55
C63H60WE10	C63	63	35	10	60
C63H60WE12	C63	63	42	12	60
C63H60WE14	C63	63	44	14	60
C63H65WE16	C63	63	48	16	65
C63H65WE20	C63	63	52	20	65
C63H80WE25	C63	63	64	25	80
C63H90WE32	C63	63	72	32	90
C80H70WE06	C80	80	25	6	70
C80H70WE08	C80	80	28	8	70
C80H70WE10	C80	80	35	10	70
C80H70WE12	C80	80	42	12	70
C80H70WE14	C80	80	44	14	70
C80H70WE16	C80	80	48	16	70
C80H70WE20	C80	80	50	20	70
C80H80WE25	C80	80	52	25	80
C80H80WE32	C80	80	65	32	80
C80H110WE40	C80	80	80	40	110

AUFSTECKFRÄSDORNE MIT POLYGONSCHAF
 POLYGONAL FACE MILL HOLDER
 ПАТРОНЫ С ПОЛИГОНАЛЬНЫМ ХВОСТОВИКОМ ДЛЯ НАСАДНЫХ ФРЕЗ

PORTE-FRAISES AVEG ATTACHEMENT POLYGONALE
 PORTAFRESE A TRASCINAMENTO FISSO CON ATTACCO POLIGONALE
 多边形端面铣刀柄

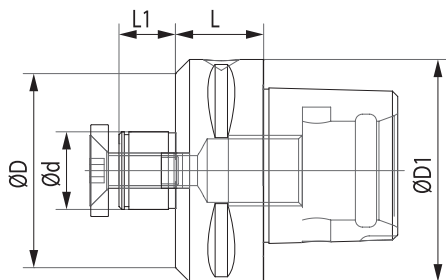

Code N.	Attacco Shank	D1 mm	D mm	d mm	L mm	L1 mm
C40H32D16	C40	40	32	16	32	17
C40H25D22	C40	40	40	22	25	19
C40H55D16	C40	40	37	16	55	17
C40H55D22	C40	40	47	22	55	19
C50H60D16	C50	50	37	16	60	17
C50H60D22	C50	50	47	22	60	19
C50H60D27	C50	50	58	27	60	21
C50H60D32	C50	50	63	32	60	24
C63H40D16	C63	63	32	16	40	17
C63H63D16	C63	63	37	16	63	17
C63H25D22	C63	63	55	22	25	19
C63H100D22	C63	63	47	22	100	19
C63H25D27	C63	63	63	27	25	21
C63H100D27	C63	63	58	27	100	21
C63H25D32	C63	63	63	32	25	24
C63H100D32	C63	63	63	32	100	24
C63H40D40	C63	63	89	40	40	27
C63H100D40	C63	63	70	40	100	27
C80H50D16	C80	80	32	16	50	17
C80H30D22	C80	80	55	22	30	19
C80H100D22	C80	80	58	22	100	19
C80H30D27	C80	80	65	27	30	21
C80H100D27	C80	80	58	27	100	21
C80H30D32	C80	80	79	32	30	24
C80H100D32	C80	80	63	32	100	24
C80H30D40	C80	80	80	40	30	27
C80H100D40	C80	80	70	40	100	27

KOMBI - AUFSTECKFRÄSDORNE
POLYGONAL COMBI-SHELL MILL ADAPTORS
КОМБИНИРОВАННЫЕ ОПРАВКИ ДЛЯ НАСАДНЫХ ФРЕЗ

MANDRINS PORTE- FRAISES A DOUBLE USAGE
MANDRINI PORTAFRESE COMBINATI CON ATTACCO POLIGONALE
复合式平面铣刀接头

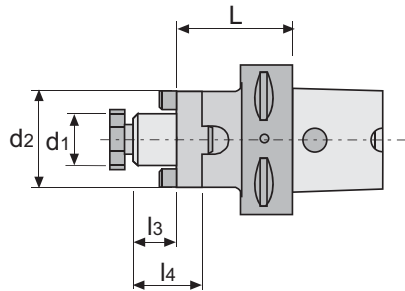

Code N.	Attacco Shank	D1 mm	L mm	l3 mm	l4 mm	d2 mm
C63H90D16	C63	16	90	17	27	32
C63H90D22	C63	22	90	19	31	40
C63H90D27	C63	27	90	21	33	48
C63H90D32	C63	32	90	24	38	58
C63H90D40	C63	40	90	27	41	70

ZWISCHENHÜSLEN FÜR MORSEKEGEL
MIT AUSTREIBBLAPPEN ODER ANZUGSGEWINDE
POLYGONAL MORSE TAPER ADAPTORS FOR DRILLS
ОПРАВКИ ДЛЯ КОНУСОВ МОРЗЕ С ЛАПКОЙ И С РЕЗЬБОЙ

DOUILLES POUR CONE MORSE A TENON ET AVEC TARAUDAGE
MANDRINI PORTAPUNTE ATTACCO CONO MORSE
CON ATTACCO POLIGONALE
莫氏锥度钻铣接头

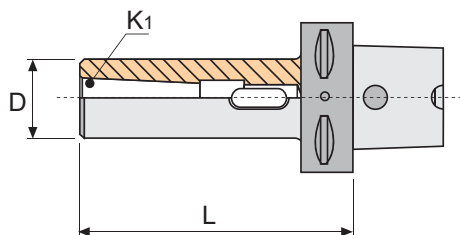

Code N.	Attacco Shank	D1 mm	A mm	L mm
C50H110CM2P	C50	32	MK2	110
C50H130CM3P	C50	40	MK3	130
C63H110CM2P	C63	32	MK2	110
C63H130CM3P	C63	40	MK3	130
C63H150CM4P	C63	52	MK4	150
C80H120CM3P	C80	40	MK3	120
C80H145CM4P	C80	52	MK4	145
C80H180CM5P	C80	63	MK5	180

NC-BOHRFUTTER UNIVERSAL DRILL CHUCKS
 УНИВЕРСАЛЬНЫЕ СВЕРЛИЛЬНЫЕ ПАТРОНЫ

MANDRINS UNIVERSELS DE PERCAGE
 MANDRINI PORTAPUNTE INTEGRALI
 万能钻夹头

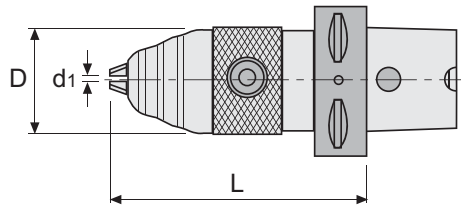

Code N.	Attacco Shank	D mm	d1 mm	L mm
C40H112R1-13	C40	50	0,5-13	112
C50H112R1-13	C50	50	0,5-13	112
C63H112R1-13	C63	50	0,5-13	112
C63H112R3-16	C63	57	3-16	112
C80H125R1-13	C80	50	0,5-13	125
C80H125R3-16	C80	57	3-16	125

REDUKTION SK50DIN69871 MIT POLYGONSCHAFT
 REDUCTION ISO50 DIN69871-AD/B - POLYGONAL SHANK
 ПЕРЕХОДНИКИ С ISO 50 DIN69871-AD/B НА EPS

REDUCTION ISO50DIN69871 AVEC ATTACHEMENT POLYGONALE
 RIDUZIONE ISO 50 DIN 69871-AD/B PER ATTACCO POLIGONALE
 缩小ISO50 DIN69871-AD/B-多边形柄

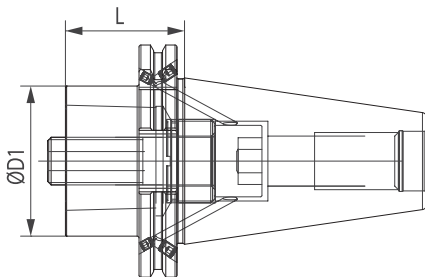

Code N.	Attacco Shank	D1 mm	L mm
TC40H40C40ADB	40DIN69871 AD/B	40	40
TC50H30C40ADB	50DIN69871 AD/B	40	30
TC50H50C63ADB	50DIN69871 AD/B	63	50
TC50H80C63ADB	50DIN69871 AD/B	63	80
TC50H70C80ADB	50DIN69871 AD/B	80	70

REDUKTION BT50MAS403BT-AD/B MIT POLYGONSCHAF
 REDUCTION ISO50 MAS403BT-AD/B - POLYGONAL SHANK
 ПЕРЕХОДНИКИ С ВТ 50 MAS403BT-AD/B НА DIN

REDUCTION ISO50MAS403BT-AD/B AVEC ATTACHEMENT POLYGONALE
 RIDUZIONE ISO 50 MAS403BT-AD/B CON ATTACCO POLIGONALE
 缩小 ISO50MAS403BT-AD/B-多边形柄

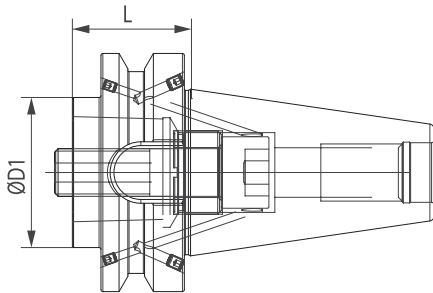

Code N.	Attacco Shank	D1 mm	L mm
BT40H30C40ADB	40MAS403BT-AD/B	40	30
BT50H70C40ADB	50MAS403BT-AD/B	40	40
BT50H50C63ADB	50MAS403BT-AD/B	63	50
BT50H90C63ADB	50MAS403BT-AD/B	63	90
BT50H70C80ADB	50MAS403BT-AD/B	80	70

GEWINDESCHNEIDFUTTER MIT POLYGONSCHAF
 POLYGONAL TAPPING HEAD
 РЕЗЬБОНАРЕЗНЫЕ ПАТРОНЫ DIN ДЛЯ МЕТЧИКОВ

MANDRIN DE TARAUDAGE AVEC ATTACHEMENT POLYGONALE
 MASCHIATORE A CAMBIO RAPIDO CON ATTACCO POLIGONALE
 多边形攻丝头

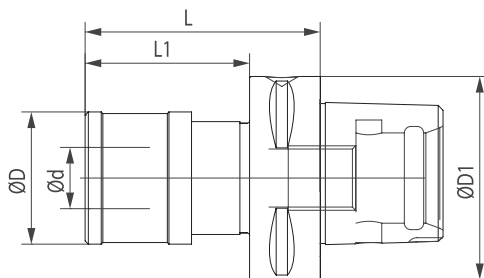

Code N.	Attacco Shank	D1 mm	D mm	d mm	L mm	L1 mm	Top range
C40GR1	C40	40	41	19	68	48	M3-M12
C40GR2	C40	40	60	31	91,5	68	M6-M20
C63GR1	C63	63	41	19	73	51	M3-M12
C63GR2	C63	63	60	31	97	75	M6-M20
C80GR1	C80	80	41	19	75	45	M3-M12
C80GR2	C80	80	60	31	93,5	63,5	M6-M20
C80GR3	C80	80	86	48	137	107	M14-M33

POLYGONSCHAFT-VERLÄNGERUNG RALLONGES AVEC ATTACHEMENT POLYGONALE
 POLYGONAL EXTENSION PROLUNGA CON ATTACCO POLIGONALE
 УДЛИНИТЕЛИ С ПОЛИГОНАЛЬНЫМ ХВОСТОВИКОМ 多边形加长型

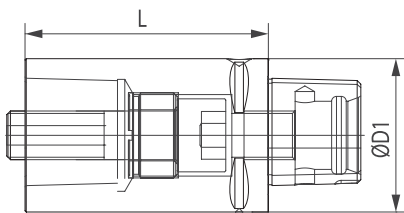

Code N.	Attacco Shank	D1 mm	L mm
C40H60C40	C40	40	60
C40H80C40	C40	40	80
C63H100C63	C63	63	100
C63H140C63	C63	63	140
C80H100C80	C80	80	100
C80H125C80	C80	80	125

POLYGONSCHAFT-ROHLING SEMI-FINIES AVEC ATTACHEMENT POLYGONALE
 POLYGONAL BLANK TOOLHOLDER MANDRINO A STELO TENERO CON ATTACCO POLIGONALE
 ЗАГОТОВКА С ПОЛИГОНАЛЬНЫМ ХВОСТОВИКОМ 多边形空白刀柄

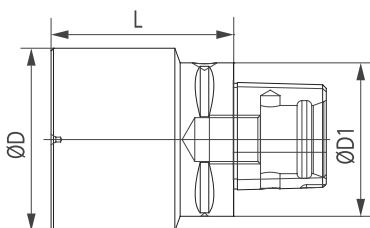

Code N.	Attacco Shank	D1	D	L mm
C40H95D40	C40	40	40	95
C40H120D40	C40	40	40	120
C40H165D60	C40	40	60	165
C40H165D63	C40	40	63	165
C40H75D80	C40	40	80	75
C40H120D80	C40	40	80	120
C40H85D100	C40	40	100	85
C50H125D50	C50	50	50	125
C50H150D50	C50	50	50	150
C50H175D75	C50	50	75	175
C50H80D90	C50	50	90	80
C50H90D110	C50	50	110	90
C50H150D95	C50	50	95	150
C50H180D63	C50	50	63	180
C63H75D91	C63	63	91	75
C63H85D110	C63	63	110	85
C63H95D130	C63	63	130	95
C63H100D115	C63	63	115	100
C63H120D110	C63	63	110	120
C63H180D63	C63	63	63	180
C63H180D120	C63	63	120	180
C63H195D75	C63	63	75	195
C80H90D130	C80	80	130	90
C80H160D120	C80	80	120	160
C80H200D80	C80	80	80	200
C80H200D100	C80	80	100	200
C80H200D145	C80	80	145	200
C80H200D150	C80	80	150	200

AXIAL BOHRSTANGENHALTER PORTE-OUTIL POUR BARRES D'ALEPAGE AXIAL
 AXIAL BORING BAR HOLDER PORTAUTENSILE PER BARENI, ASSIALE
 ДЕРЖАТЕЛИ ОСЕВЫЕ ДЛЯ РАСТОЧНЫХ РЕЗЦОВ 轴向镗杆刀柄

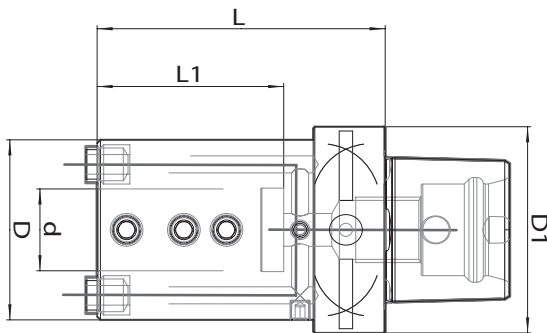

Code N.	Attacco Shank	D	D1	d	L	L1
C40H65D12E2	C40	36	40	12	65	40
C40H70D16E2	C40	40	40	16	70	42
C40H70D20E2	C40	45	40	20	70	42
C50H70D12E2	C50	40	50	12	70	40
C50H80D16E2	C50	45	50	16	80	50
C50H80D20E2	C50	50	50	20	80	50
C50H80D25E2	C50	55	50	25	80	50
C63H80D16E2	C63	45	63	16	80	50
C63H80D20E2	C63	50	63	20	80	50
C63H80D25E2	C63	55	63	25	88	57
C63H95D32E2	C63	72	63	32	95	59
C63H105D40E2	C63	80	63	40	105	72
C80H85D16E2	C80	45	80	16	85	48
C80H85D20E2	C80	50	80	20	85	48
C80H85D25E2	C80	55	80	25	85	48
C80H95D32E2	C80	72	80	32	95	58
C80H110D40E2	C80	80	80	40	110	73

REDUZIERHÜSLEN MIT POLYGONSCHAFT
POLYGONAL BORING BAR ADAPTER
ПАТРОНЫ DIN ДЛЯ РАСТОЧНЫХ ДЕРЖАВОК

DOUILLES AVEC ATTACHEMENT POLYGONALE
ADATTATORE PER PUNTE CON ATTACCO POLIGONALE
多边形镗孔适配器

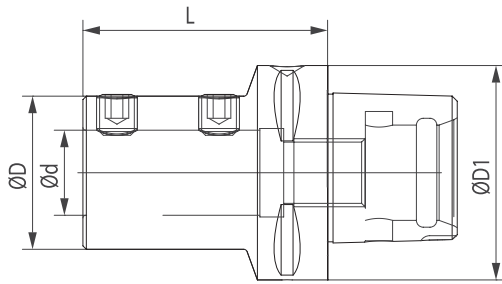

Code N.	Attacco Shank	D mm	D1 mm	d mm	L mm
C40H50D08PNT	C40	44	40	8	50
C40H50D10PNT	C40	44	40	10	50
C40H50D12PNT	C40	44	40	12	50
C40H56D16PNT	C40	36	40	16	56
C40H60D20PNT	C40	40	40	20	60
C40H77D25PNT	C40	45	40	25	77
C50H52D08PNT	C50	44	50	8	52
C50H52D10PNT	C50	44	50	10	52
C50H52D12PNT	C50	44	50	12	52
C50H52D16PNT	C50	44	50	16	52
C50H52D20PNT	C50	44	50	20	52
C50H60D25PNT	C50	44	50	25	60
C63H60D08PNT	C63	44	63	8	60
C63H60D10PNT	C63	44	63	10	60
C63H60D12PNT	C63	44	63	12	60
C63H70D16PNT	C63	36	63	16	70
C63H70D20PNT	C63	40	63	20	70
C63H72D25PNT	C63	45	63	25	72
C63H75D32PNT	C63	52	63	32	75
C63H85D40PNT	C63	98	63	40	85
C80H80D16PNT	C80	36	80	16	80
C80H80D20PNT	C80	40	80	20	80
C80H85D25PNT	C80	45	80	25	85
C80H90D32PNT	C80	52	80	32	90
C80H95D40PNT	C80	98	80	40	95

90° DREHHALTER MIT POLYGONSCHAFT
90° POLYGONAL TOOLHOLDER
ПАТРОНЫ DIN ДЛЯ ДЕРЖАВОК ДЛЯ НАРУЖНОГО ТОЧЕНИЯ 90 ГРАДУСОВ

PORTE-OUTIL 90° AVEC ATTACHEMENT POLYGONALE
PORTAUTENSILE 90° CON ATTACCO POLIGONALE
90° 多边形刀柄

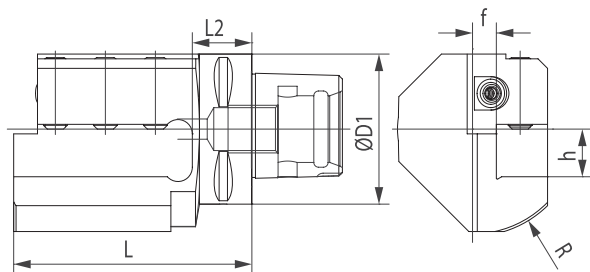

Code N.	Attacco Shank	D1 mm	L mm	h mm
C50-AD2020R/L	C50	50	98	20
C63-AD2020R/L	C63	63	100	20
C63-AD2525R/L	C63	63	130	25
C63-AD3232R/L	C63	63	134	32
C80-AD3232R/L	C80	80	140	32

45° DREHNHALTER MIT POLYGONSCHAFT 45° POLYGONAL TOOLHOLDER
 PATRONY DIN DLA DERZHAVOK DLA NARUZHNOGO TOCHENIA 45 GRADUSOV

PORTE-OUTIL 45° AVEC ATTACHEMENT POLYGNONALE
 PORTAUTENSILE 45° CON ATTACCO POLIGONALE
 45° 多边形刀柄

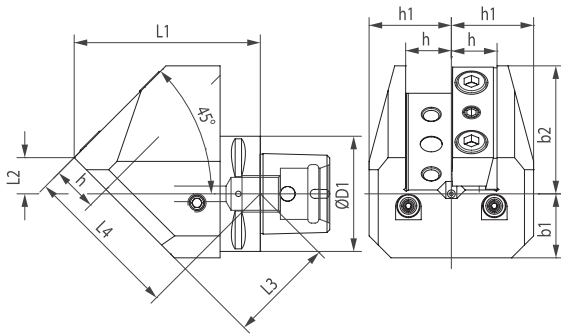

Code N.	Attacco Shank	D1 mm	b1 mm	b2 mm	h mm	h1 mm	L1 mm	L2 mm	L3 mm	L4 mm
C63-ARD2525-45	C63	63	35	70	25	45	102	20	58	86

45° DREHNHALTER MIT POLYGONSCHAFT 45° POLYGONAL TOOLHOLDER
 PATRONY DIN DLA DERZHAVOK DLA NARUZHNOGO TOCHENIA 45 GRADUSOV

PORTE-OUTIL 45° AVEC ATTACHEMENT POLYGNONALE
 PORTAUTENSILE 45° CON ATTACCO POLIGONALE
 45° 多边形刀柄

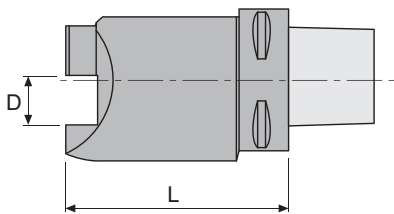

Code N.	Attacco Shank	D mm	L mm
C50AR20R/L	C50	20	100
C63AR20R/L	C63	20	100
C63AR25R/L	C63	25	130
C80AR32R/L	C80	32	135

KLEMMHALTER MIT POLYGONSCHAFT
POLYGONAL TURNING TOOL
ДЕРЖАВКА ДЛЯ НАРУЖНОГО ТОЧЕНИЯ DIN

PORTE-OUTIL AVEC ATTACHEMENT POLYGONALE
UTENSILE TORNITURA CON ATTACCO POLIGONALE
多边形车刀

PCLN

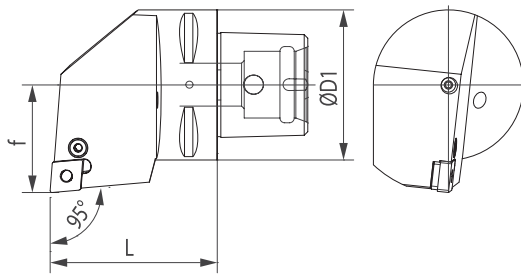

Code N.	Attacco Shank	D1 mm	f mm	L mm	Insert
C40-PCLNR/L12	C40	40	27	50	CN..1204..
C50-PCLNR/L12	C50	50	35	60	CN..1204..
C63-PCLNR/L12	C63	63	45	65	CN..1204..
C80-PCLNR/L12	C80	80	55	80	CN..1204..
C40-PCLNR/L16	C40	40	27	50	CN..1606..
C50-PCLNR/L16	C50	50	35	60	CN..1606..
C63-PCLNR/L16	C63	63	45	65	CN..1606..
C80-PCLNR/L16	C80	80	55	80	CN..1606..

KLEMMHALTER MIT POLYGONSCHAFT
POLYGONAL TURNING TOOL
ДЕРЖАВКА ДЛЯ НАРУЖНОГО ТОЧЕНИЯ DIN

PORTE-OUTIL AVEC ATTACHEMENT POLYGONALE
UTENSILE TORNITURA CON ATTACCO POLIGONALE
多边形车刀

PDJN

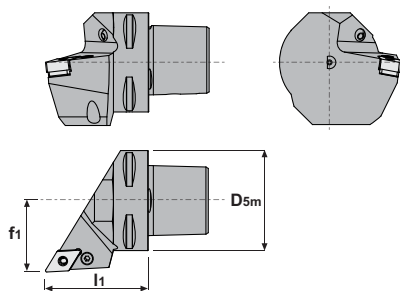

Code N.	Attacco Shank	l1 mm	f1 mm	Insert
C40-PDJNR/L15	40	55	27	DN..1506..
C50-PDJNR/L15	50	60	35	DN..1506..
C63-PDJNR/L15	63	65	45	DN..1506..
C80-PDJNR/L15	80	80	55	DN..1506..

KLEMMHALTER MIT POLYGONSCHAFT
POLYGONAL TURNING TOOL
ДЕРЖАВКА ДЛЯ НАРУЖНОГО ТОЧЕНИЯ DIN

PORTE-OUTIL AVEC ATTACHEMENT POLYGONALE
UTENSILE TORNITURA CON ATTACCO POLIGONALE
多边形车刀

SCLC

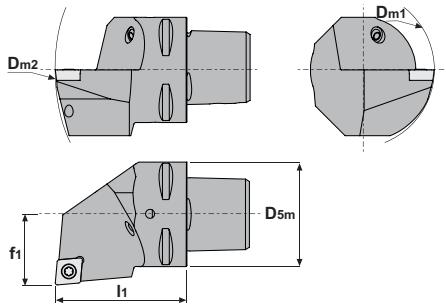

Code N.	Attacco Shank	l1 mm	f1 mm	Insert
C40-SCLCR/L09	40	50	27	CC..09T3..
C50-SCLCR/L09	50	60	35	CC..09T3..
C63-SCLCR/L09	63	65	45	CC..09T3..
C40-SCLCR/L12	40	50	27	CC..1204..
C50-SCLCR/L12	50	60	35	CC..1204..
C63-SCLCR/L12	63	65	45	CC..1204..

KLEMMHALTER MIT POLYGONSCHAFT
POLYGONAL TURNING TOOL
ДЕРЖАВКА ДЛЯ НАРУЖНОГО ТОЧЕНИЯ DIN

PORTE-OUTIL AVEC ATTACHEMENT POLYGONALE
UTENSILE TORNITURA CON ATTACCO POLIGONALE
多边形车刀

SDJC

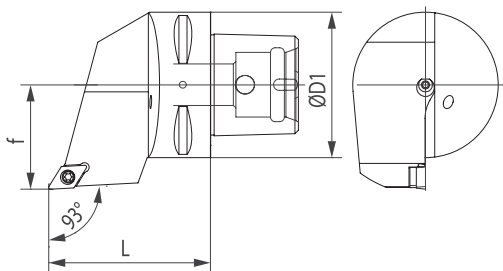

Code N.	Attacco Shank	D1 mm	f mm	L mm	Insert
C40-SDJCR/L11	C40	40	27	50	DC..11T3..
C50-SDJCR/L11	C50	50	35	60	DC..11T3..
C63-SDJCR/L11	C63	63	45	65	DC..11T3..

KLEMMHALTER MIT POLYGONSCHAFT
POLYGONAL TURNING TOOL
ДЕРЖАВКА ДЛЯ НАРУЖНОГО ТОЧЕНИЯ DIN

PORTE-OUTIL AVEC ATTACHEMENT POLYGONALE
UTENSILE TORNITURA CON ATTACCO POLIGONALE
多边形车刀

SVHB

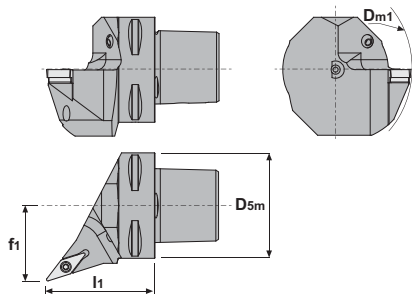

Code N.	Attacco Shank	l1 mm	f1 mm	Insert
C40-SVHBR/L16	40	50	27	VBMT1604..
C50-SVHBR/L16	50	60	35	VBMT1604..
C63-SVHBR/L16	63	65	45	VBMT1604..

KLEMMHALTER MIT POLYGONSCHAFT
POLYGONAL TURNING TOOL
ДЕРЖАВКА ДЛЯ НАРУЖНОГО ТОЧЕНИЯ DIN

PORTE-OUTIL AVEC ATTACHEMENT POLYGONALE
UTENSILE TORNITURA CON ATTACCO POLIGONALE
多边形车刀

SVHC

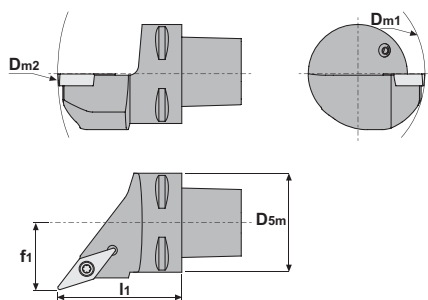

Code N.	Attacco Shank	l1 mm	f1 mm	Insert
C40-SVHCR/L16	40	50	27	VCMT1604..
C50-SVHCR/L16	50	60	35	VCMT1604..
C63-SVHCR/L16	63	65	45	VCMT1604..

KLEMMHALTER MIT POLYGONSCHAFT
POLYGONAL TURNING TOOL
ДЕРЖАВКА ДЛЯ НАРУЖНОГО ТОЧЕНИЯ DIN

PORTE-OUTIL AVEC ATTACHEMENT POLYGONALE
UTENSILE TORNITURA CON ATTACCO POLIGONALE
多边形车刀

SVJB

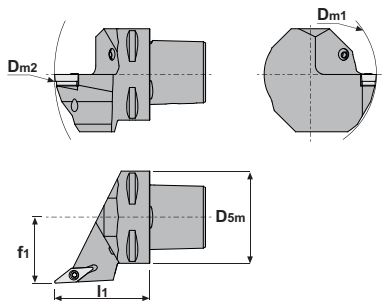

Code N.	Attacco Shank	l1 mm	f1 mm	Insert
C40-SVJBR/L16	40	50	27	VBMT1604..
C50-SVJBR/L16	50	60	35	VBMT1604..
C63-SVJBR/L16	63	65	45	VBMT1604..

KLEMMHALTER MIT POLYGONSCHAFT
POLYGONAL TURNING TOOL
ДЕРЖАВКА ДЛЯ НАРУЖНОГО ТОЧЕНИЯ DIN

PORTE-OUTIL AVEC ATTACHEMENT POLYGONALE
UTENSILE TORNITURA CON ATTACCO POLIGONALE
多边形车刀

SVJC

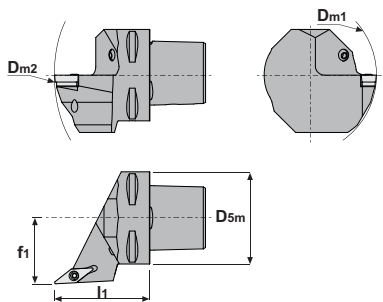

Code N.	Attacco Shank	l1 mm	f1 mm	Insert
C40-SVJCR/L16	40	50	27	VCMT1604..
C50-SVJCR/L16	50	60	35	VCMT1604..
C63-SVJCR/L16	63	65	45	VCMT1604..

KLEMMHALTER MIT POLYGONSCHAFT
POLYGONAL TURNING TOOL
ДЕРЖАВКА ДЛЯ НАРУЖНОГО ТОЧЕНИЯ DIN

PORTE-OUTIL AVEC ATTACHEMENT POLYGONALE
UTENSILE TORNITURA CON ATTACCO POLIGONALE
多边形车刀

SVVB

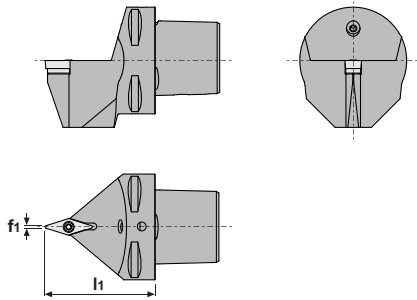

Code N.	Attacco Shank	l1 mm	f1 mm	Insert
C40-SVVB16-140	40	0,6	50	VBMT1604..
C50-SVVB16-165	50	0,6	60	VBMT1604..
C63-SVVB16-190	63	0,6	65	VBMT1604..

KLEMMHALTER MIT POLYGONSCHAFT
POLYGONAL TURNING TOOL
ДЕРЖАВКА ДЛЯ НАРУЖНОГО ТОЧЕНИЯ DIN

PORTE-OUTIL AVEC ATTACHEMENT POLYGONALE
UTENSILE TORNITURA CON ATTACCO POLIGONALE
多边形车刀

SVVC

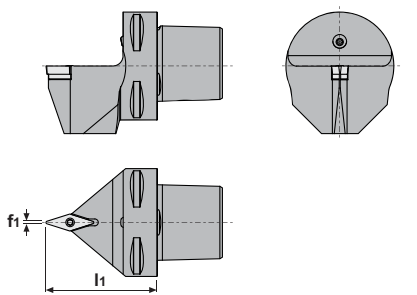

Code N.	Attacco Shank	l1 mm	f1 mm	Insert
C40-SVVC16-140	40	0,6	50	VCMT1604..
C50-SVVC16-165	50	0,6	60	VCMT1604..
C63-SVVC16-190	63	0,6	65	VCMT1604..

KLEMMHALTER MIT POLYGONSCHAFT PORTE-OUTIL AVEC ATTACHEMENT POLYGALE
 POLYGONAL TURNING TOOL UTENSILE TORNITURA CON ATTACCO POLIGONALE
 ДЕРЖАВКА ДЛЯ НАРУЖНОГО ТОЧЕНИЯ DIN 多边形车刀

PCLN

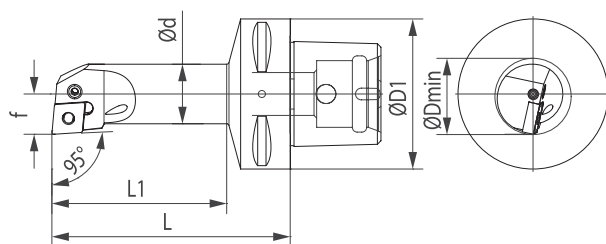

Code N.	Attacco Shank	D min mm	D1 mm	f mm	L mm	L3 mm	d mm	Insert
C40-25PCLNR/L12	C40	32	25	17	90	69	25	CN..1204..
C40-32PCLNR/L12	C40	40	32	22	110	89	32	CN..1204..
C40-40PCLNR/L12	C40	50	40	27	120	100	40	CN..1204..
C50-25PCLNR/L12	C50	32	25	17	90	67	25	CN..1204..
C50-32PCLNR/L12	C50	40	32	22	110	88	32	CN..1204..
C50-40PCLNR/L12	C50	50	40	27	140	119	40	CN..1204..
C50-50PCLNR/L16	C50	63	50	35	150	131	35	CN..1606..
C63-25PCLNR/L12	C63	32	63	17	100	74	25	CN..1204..
C63-32PCLNR/L12	C63	40	32	22	110	84	32	CN..1204..
C63-40PCLNR/L16	C63	50	40	27	140	119	27	CN..1606..
C63-50PCLNR/L16	C63	63	50	35	175	152	35	CN..1606..

KLEMMHALTER MIT POLYGONSCHAFT PORTE-OUTIL AVEC ATTACHEMENT POLYGALE
 POLYGONAL TURNING TOOL UTENSILE TORNITURA CON ATTACCO POLIGONALE
 ДЕРЖАВКА ДЛЯ НАРУЖНОГО ТОЧЕНИЯ DIN 多边形车刀

PDUN

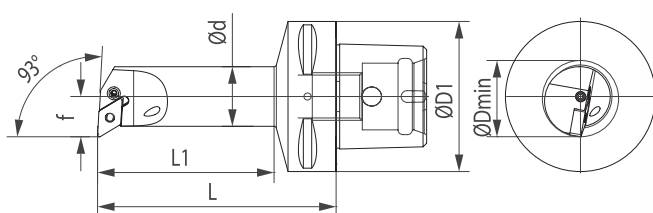

Code N.	Attacco Shank	D min mm	D1 mm	f mm	L mm	L3 mm	d mm	Insert
C40-40PDUNR/L15	C40	50	40	27	120	100	40	DN..1506..
C50-40PDUNR/L15	C50	50	40	27	140	119	40	DN..1506..
C50-50PDUNR/L15	C50	63	50	35	150	131	50	DN..1506..
C63-25PDUNR/L11	C63	32	63	17	100	74	25	DN..1104..
C63-32PDUNR/L15	C63	40	32	22	110	84	32	DN..1506..
C63-40PDUNR/L15	C63	50	40	27	140	115	40	DN..1506..
C63-50PDUNR/L15	C63	63	50	35	175	152	50	DN..1506..

KRAFTSPANNFUTTER MIT POLYGONSCHAFT MANDRINS A FORT SERRAGE AVEC ATTACHEMENT POLYGONALE
 POLYGONAL MILLING CHUCK MANDRINI FORTE SERRAGGIO CON ATTACCO POLIGONALE
 СИЛОВЫЕ ПАТРОНЫ 铣夹头

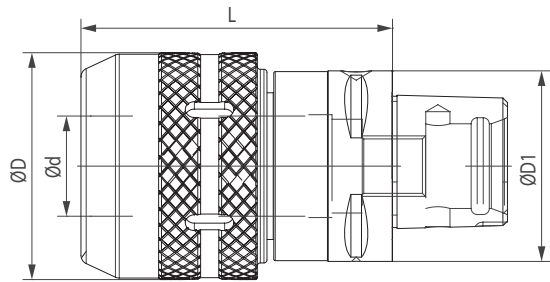

Code N.	Shank	D1	D	d	L
C63H80C20	C63	63	54	20	80
C63H100C32	C63	63	72	32	100
C80H75C20	C80	80	54	20	75
C80H95C32	C80	80	72	32	95

AXIAL WERKZEUGHALTER MIT POLYGONSCHAFT KUPPLUNG PORTE-UTIL AXIAL AVEC ATTACHEMENT POLYGONALE
 AXIAL TOOLHOLDER WITH POLYGONAL COUPLING PORTAUTENSILE ASSIALE PER UTENSILI CON ATTACCO POLIGONALE
 ДЕРЖАТЕЛИ ИНСТРУМЕНТА С ХВОСТОВИКОМ НСК ОСЕВЫЕ 多边形耦合轴向刀柄

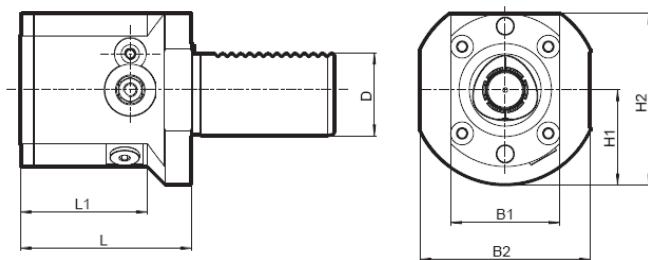

Code N.	Attacco Shank	L	L1	D	B1	B2	H1	H2
VDI40L75C40R/L	C40	75	56	40	48	75	41	75
VDI40L85C50R/L	C50	85	72	40	64	75	41	83
VDI40L109C63R/L	C63	109	109	40	84	84	52	104
VDI50L85C50R/L	C50	85	62	50	64	83	49	91
VDI50L105C63R/L	C63	105	105	50	84	84	52	104
VDI60L95C63R/L	C63	95	59	60	84	84	58	111

WERKZEUGHALTER MIT ZYLINDRISCHEM SCHAFT
UND MIT POLYGONSCHAFT KUPPLUNG
TOOLHOLDER WITH CYLINDRICAL SHANK
AND WITH POLYGONAL ATTACHMENT
ДЕРЖАТЕЛИ С ЦИЛИНДРИЧЕСКИМ ХВОСТОВИКОМ
ДЛЯ ИНСТРУМЕНТА С ХВОСТОВИКОМ HSK

PORTE-OUTIL AVEC QUEUE CYLINDRIQUE
ET AVEC ATTACHEMENT POLYGONALE
PORTAUTENSILE A STELO CILINDRICO
CON ATTACCO POLIGONALE
帶多边形附件的圆柱杆刀柄

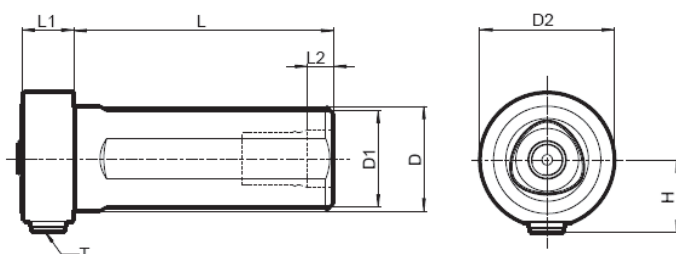

Code N.	Attacco Shank	L	L1	L2	D	D1	H	T
D40L100C40	C40	100	20	10	40	37	28	1/8 G
D50L120C50	C50	120	24	20	50	47	33	1/8 G

WERKZEUGHALTER MIT VIERECKIGEM SCHAFT
UND MIT POLYGONSCHAFT KUPPLUNG
TOOLHOLDER WITH SQUARE SHANK
AND WITH POLYGONAL ATTACHMENT
ДЕРЖАТЕЛИ С ПРИЗМАТИЧЕСКИМ ХВОСТОВИКОМ
ДЛЯ ИНСТРУМЕНТА С ХВОСТОВИКОМ HSK

PORTE-OUTIL AVEC QUEUE CARÉE
ET AVEC ATTACHEMENT POLYGONALE
PORTAUTENSILE A STELO QUADRO
CON ATTACCO POLIGONALE
帶多边形附件的方杆刀柄

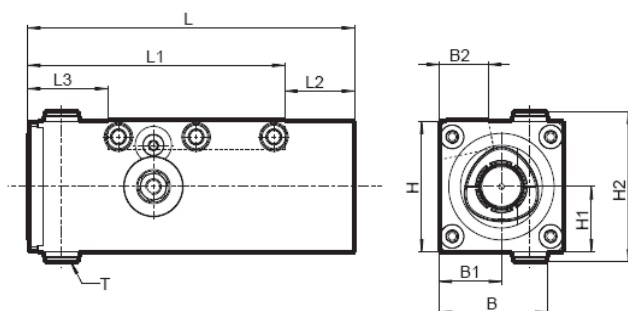

Code N.	Misura	L	L1	L2	L3	B	B1	B2	H	H1	H2	T
Q50L125C40R/L	C40	125	100	25	31	42	24	19	50	25	57,5	G 1/8
Q63L145C50R/L	C50	145	118	27	36	64	32	32	64	32	68	G 1/8

MONTAGEBLOCK SUPPORTS D'ASSEMBLAGE
 ASSEMBLY SUPPORTS SUPPORTO DI MONTAGGIO
 СТОЙКА ДЛЯ СБОРКИ ИНСТРУМЕНТА 组件支架

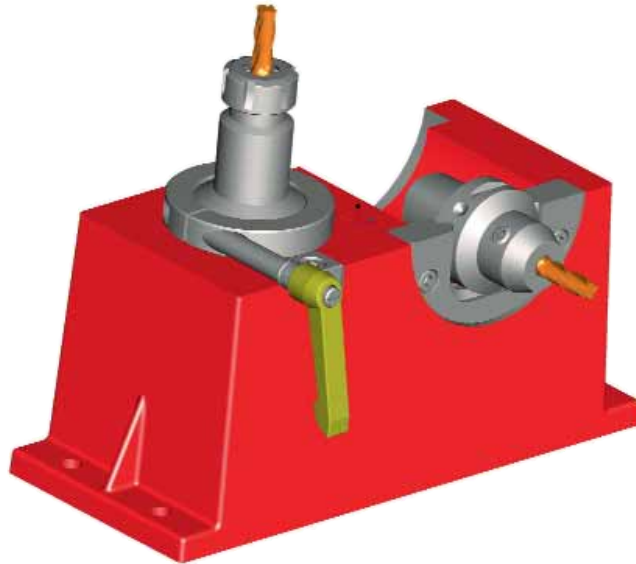

Attack	Code N
C3	237-33110
C4	237-33210
C5	237-33310
C6	237-33410
C8	237-33510
C10	237-33610

Dieses unkompliziertes System erlaubt die schnelle und sichere Montage und Demontage von Steilkegelaufnahmen in horizontaler und vertikaler Lage. Das Risiko der Werkzeugbeschädigung ist ausgeschlossen. Es eignet sich natürlich auch für modulare Din-Aufnahmen.

It is very useful for all assembly and disassembly operations of the tools on the toolholders, either in horizontal or in vertical position. This process is carried out without any risk to damage casually the tool or the toolholder. It is a very simple system suitable for Din toolholders.

Приспособление очень удобно для операций сборки и демонтажа инструмента, как в вертикальном, так и в горизонтальном положении. Оно позволяет избежать повреждения оправок или режущего инструмента. Это простое приспособление подходит для монолитных оправок.

Il permet de effectuer toutes les opérations de montage /assemblage/ de montage des outils sur les Mandrins. Ces proces se déroulent avec rationalité, sûreté, vitesse et sans aucun risque d'endommagement accidentel du mandrin ou de l'outil. C'est un système qui vous offre la plus haute simplicité d'usage et il est bien indiqué pour les Din mandrin.

Consente di effettuare tutte le operazioni di montaggio e smontaggio degli utensili sui mandrini, sia in orizzontale che in verticale. Questi procedimenti avvengono con razionalità, sicurezza, rapidità e senza alcun rischio di danneggiare o il mandrino o l'utensile. E' il sistema che offre la massima semplicità d'uso per i mandrini Poligonali.

它对于所有将工具以垂直或水平方向安装在刀柄上和从刀柄上拆除，均非常有用。这一过程的执行不会对工具或刀柄产生任何破坏的风险。这一非常简单的系统适用于整体式刀柄。